

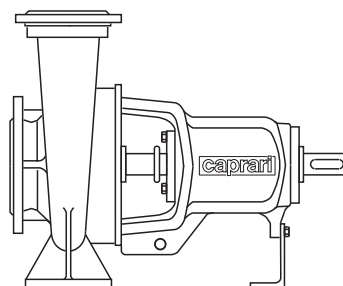

End-suction centrifugal pumps EN 733
compliant with UNI EN 12845 and UNI EN 12259-12 standards
*Pompes centrifuges à aspiration axiale selon la norme EN 733
conformes aux normes UNI EN 12845 et UNI EN 12259-12*
**Pompe centrifughe ad aspirazione assiale normalizzate EN 773
conformi alle norme UNI EN 12845 e UNI EN 12259-12**

NC.E



caprari

ISO 9001
ISO 14001
ISO 45001
BUREAU VERITAS
Certification



	Page - Page - Pagina
<ul style="list-style-type: none"> • Technical data <i>Données techniques</i> Dati tecnici 	3
<ul style="list-style-type: none"> • Technical data - Pump coding <i>Données techniques - Identification du sigle</i> Dati tecnici- Esempificazione sigla 	4
<ul style="list-style-type: none"> • Performance ranges - Operating limits <i>Champs de performances - Limites de fonctionnement</i> Campi di prestazione - Limiti di funzionamento 	5
<ul style="list-style-type: none"> • Pump construction and materials <i>Construction de la pompe et matériels</i> Costruzione pompa e materiali 	6
<ul style="list-style-type: none"> • Performances curves <i>Caractéristiques de fonctionnement</i> Caratteristiche di funzionamento 	9
<ul style="list-style-type: none"> • Overall dimensions and weights <i>Dimensions d'encombrement et poids</i> Dimensioni di ingombro e pesi 	39
Flanges (UNI EN 1092-2) - Brides (UNI EN 1092-2) - Flange (UNI EN 1092-2)	42

APPLICATIONS

EN 733 end-suction pumps compliant with European standards UNI EN 12845 and UNI EN 12259-12, ideal for the construction of fire-fighting units with electric or internal combustion engines.

GENERAL INFORMATION

- Pump casing:
volute type with flanged delivery port.
- Impeller:
high efficiency closed type with balanced axial thrust in AISI 316 stainless steel/bronze
- Impeller wear ring:
in bronze
- Shaft and supports:
the stainless steel shaft (fully protected against contact with the pumped water) is guided and supported by two ball bearings housed in the connecting support that are permanently lubricated with high quality grease to guarantee longer life.
- Seal:
the mechanical type, housed in the connecting support and easily replaceable.
- Coupling to the motor:
the NC.E series pumps can be coupled to IP 55 standard electric motors with B3 motor mounting or internal combustion engine.
The BACK PULL OUT constructional concept, connection to the motor with a flexible coupling and spacer, available on request, allow the wet end to be disassembled from the rear for inspection purposes and repairs without disconnecting the motor or the pump casing from the piping.
- Direction of rotation:
clockwise viewed from drive side.
- Port positioning:
axial for suction / radial delivery port pointing upwards.

LIMITS

- Max. temperature of pumped liquid: +90°C
- Min. temperature of pumped liquid: -10°C
- Max operating time with closed discharge and liquid at 90°C: 30 sec.
- The pumps can operate with all fluids chemically and mechanically compatible with the pump materials.

APPLICATIONS

Pompes normalisées EN733 conformes aux normes UNI EN 12845 et UNI EN 12259-12, idéales pour la réalisation de groupes incendie avec moteurs électriques ou endothermiques.

CARACTÉRISTIQUES

- Corps de pompe :
type à volute avec orifice de refoulement à bride.
 - Roue :
de type fermé à haut rendement, avec équilibrage et la poussée axiale en acier inoxydable AISI 316/bronze
 - Bague d'usure:
en bronze
 - Arbre et paliers:
l'arbre en acier inoxydable, (totalement protégé du contact avec l'eau pompée) est guidé et soutenu par deux roulements à billes logés dans le palier de liaison à lubrification permanente par de la graisse haute qualité, en garantie d'une très longue durée.
 - Garniture:
de type mécanique logée dans le palier de liaison et facile à remplacer.
 - Accouplement au moteur:
les pompes série NC.E peuvent être accouplées à des moteurs électriques suivant le standard IP 55 dans la forme de construction B3; la pompe peut être accouplée à des moteurs à haut rendement. Le principe de fabrication «BACK PULL OUT» ainsi que l'accouplement au moteur par joint élastique et entretoise d'espacement sur demande permettent de démonter la partie hydraulique par l'arrière pour les contrôles techniques ou la réparation, sans débrancher le moteur et le corps de la pompe des tuyauteries.
 - Sens de rotation :
horaire vu côté commande.
 - Orientation des orifices :
aspiration axiale / orifice de refoulement radiale tourné vers le haut.
- LIMITES D'EMPLOI**
- *Température max. du liquide pompé : +90°C*
 - *Température min. du liquide pompé : -10°C*
 - *Temps max. de fonctionnement à refoulement fermé avec liquide à 90°C: 30 s.*
 - *Possibilité de véhiculer de nombreux liquides chimiquement et mécaniquement agressifs, compatibles avec les matériaux constitutifs des pompes.*

APPLICAZIONI

Pompe normalizzate EN 733 conformi alle Norme europee UNI EN 12845 e UNI EN 12259-12, ideali per la realizzazione di gruppi antincendio con motori elettrici o endothermici.

CARATTERISTICHE

- Corpo pompa:
del tipo a voluta con bocca premente flangiata.
 - Girante:
del tipo chiuso ad elevato rendimento, con equilibratura della spinta assiale in acciaio inox AISI 316/bronzo.
 - Anello sede girante:
in bronzo.
 - Albero e supporti:
l'albero in acciaio inossidabile (totalmente protetto dal contatto con l'acqua pompata) è guidato e sostenuto da due cuscinetti a sfere alloggiati nel supporto di collegamento e lubrificati a grasso permanente di alta qualità a garanzia di una più lunga durata.
 - Tenuta:
di tipo meccanico alloggiata nel supporto di collegamento e facilmente sostituibile.
 - Accoppiamento al motore:
le pompe serie NC.E, possono essere accoppiate a motori elettrici standard IP 55 in forma costruttiva B3 o motore endotermico. Il concetto costruttivo BACK PULL OUT e l'accoppiamento al motore con giunto elastico e distanziale spaziatore su richiesta consentono lo smontaggio posteriore della parte idraulica per l'ispezione o la riparazione, senza sconnettere il motore ed il corpo pompa dalle tubazioni.
 - Senso di rotazione:
orario visto dal lato comando.
 - Orientamento bocche:
aspirante assiale / premente radiale rivolta verso l'alto.
- LIMITI D'IMPIEGO**
- *Temperatura max. liquido sollevato: +90°C.*
 - *Temperatura min. liquido sollevato: -10°C.*
 - *Tempo max di funzionamento a bocca chiusa con liquido a 90°C.: 30 sec.*
 - *Possibilità di veicolamento di tutti quei liquidi chimicamente e meccanicamente compatibili con i materiali costruttivi delle pompe.*

PUMP CODING
IDENTIFICATION DU SIGLE
ESEMPLIFICAZIONE SIGLA

Code - Désignation - Sigla
NC100-200EK/214-2900 - NC100-200EC/170-2900

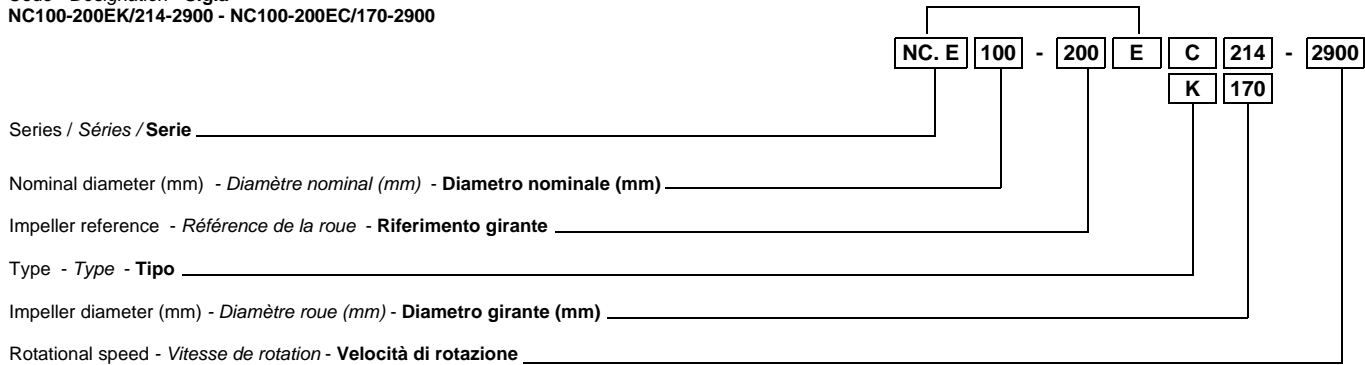

MECHANICAL SEAL

ÉTANCHÉITÉ MÉCANIQUE

TENUTA MECCANICA

Type Type Tipo	Component / Particulier / Particolare			
	Ressort Spring Molla	Joints Gaskets Guarnizioni	Static seat Grain fixe Anello fisso	Rotatic seat Grain tournant Anello rotante
Material/ Matériel / Materiale				
Standard	AISI 316	EPDM	SILICON CARBIDE CARBURE DE SILICIUM CARBURO DI SILICIO	SILICON CARBIDE CARBURE DE SILICIUM CARBURO DI SILICIO

PUMPED LIQUID

Conforming to : DIN 24960 - ISO 3069.

TOLERANCES

Service conditions have been measured with cold water (15°C - 59°F) at 1 bar atmospheric pressure. These tolerances are guaranteed with standard assembly line pumps built according to UNI/ISO 9906 Grade 2B.

Catalogue data are for liquids with a density of 1 kg/dm³, and kinematic viscosity not exceeding 1 mm²/s.

LIQUIDE À POMPER

Normalisé : DIN 24960 - ISO 3069.

TOLERANCES

Les caractéristiques de fonctionnement ont été mesurées avec de l'eau froide (15°C.) à la pression atmosphérique (1bar). Comme il s'agit de pompes construites en séries, elles sont garanties selon les normes UNI/ISO 9906 Niveau 2B.

Les données du catalogue se réfèrent à des liquides ayant une densité de 1 kg/dm³ et une viscosité cinématique qui ne dépasse pas 1 mm²/s.

LIQUIDO DA SOLLEVARE

Secondo le norme : DIN 24960 - ISO 3069.

TOLLERANZE

Le caratteristiche di funzionamento sono state rilevate con acqua fredda (15°C) alla pressione atmosferica (1bar) e vengono garantite, trattandosi di pompe costruite in serie, secondo le norme UNI/ISO 9906 grado 2B.

I dati di catalogo si riferiscono a liquidi con densità di 1kg/dm³ e con viscosità cinematica non superiore a 1mm²/s.

Performance ranges
Champs de performance
Campi di prestazione

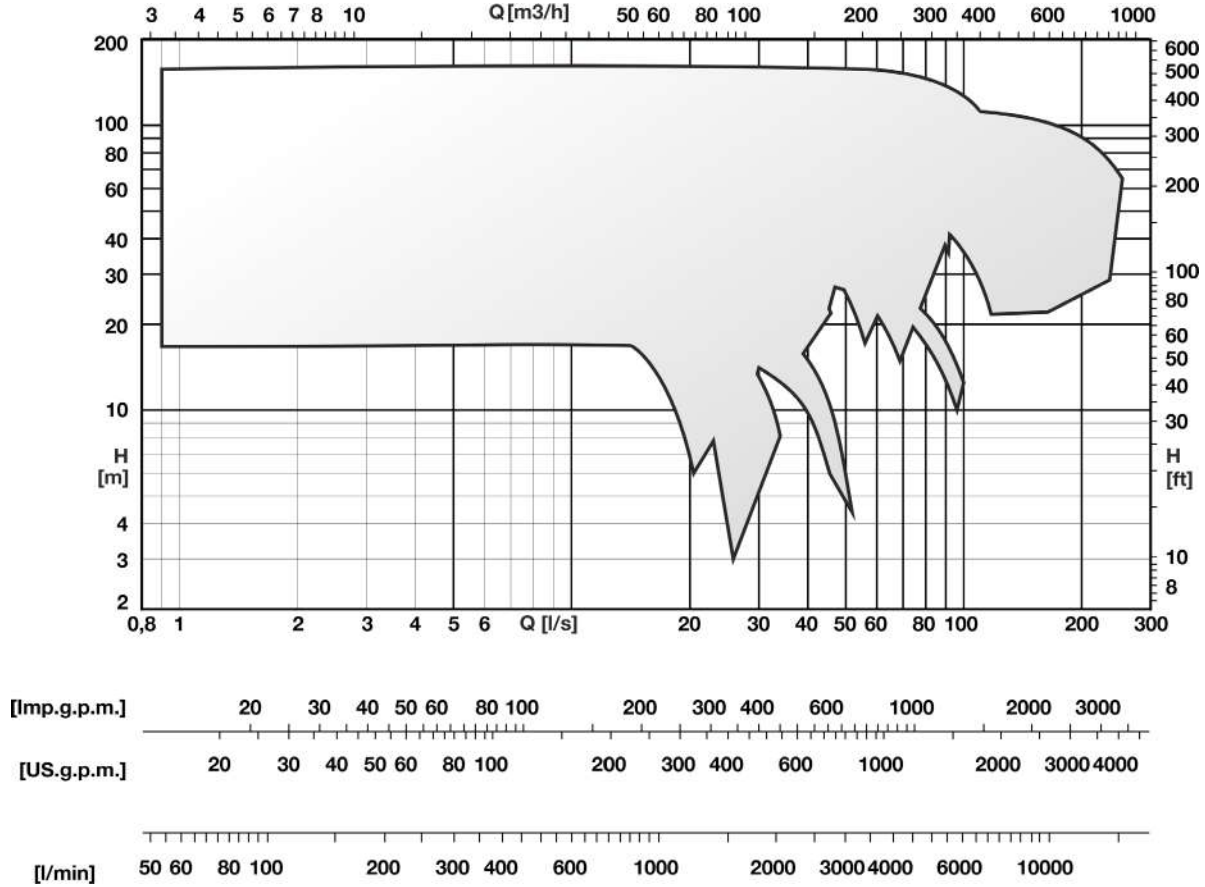

OPERATING LIMITS / LIMITES DE FONCTIONNEMENT / LIMITI DI FUNZIONAMENTO

Type Type Tipo	Rpm max [min ⁻¹]	QR [l/s]	P2 max [kW]
NC32-200EC/204-2900	2900	5.8	6.9
NC32-250EK/225-2900	2900	6.2	11.8
NC32-250EK/235-2900	2900	6.7	13.3
NC32-250EK/245-2900	2900	7	14.7
NC32-250EK/255-2900	2900	7.4	16.2
NC32-250EK/264-2900	2900	7.7	17.3
NC40-200EK/175-2900	2900	7.1	6.2
NC40-200EK/185-2900	2900	7.1	7.2
NC40-200EK/195-2900	2900	8.1	8.2
NC40-200EK/205-2900	2900	8.5	9.1
NC40-200EK/214-2900	2900	8.7	10
NC40-250EC/215-2900	2900	8.3	9.8
NC40-250EK/225-2900	2900	8.6	10
NC40-250EC/227-2900	2900	8.3	12.9
NC40-250EK/235-2900	2900	9.1	11.6
NC40-250EK/245-2900	2900	9.4	13.6
NC40-250EC/251-2900	2900	10.5	16.5
NC40-250EK/255-2900	2900	9.7	16.8
NC40-250EK/264-2900	2900	10	20.6
NC50-125EK/120-2900	2900	14.6	4.4
NC50-125EK/130-2900	2900	16.7	5.9
NC50-125EK/139-2900	2900	19.6	7.1
NC50-160EK/135-2900	2900	11.4	4.1
NC50-160EK/145-2900	2900	12.8	5.5
NC50-160EK/155-2900	2900	14.2	7.2
NC50-160EK/165-2900	2900	16.3	9.3
NC50-160EC/174-2900	2900	15	7.3
NC50-160EK/174-2900	2900	17.6	11.4
NC50-200EC/194-2900	2900	18.3	14.3
NC50-200EC/206-2900	2900	20.8	18
NC50-200EC/216-2900	2900	20.8	21.9
NC50-250EC/218-2900	2900	16.7	21.8
NC50-250EC/242-2900	2900	18.3	30.3
NC50-250EC/256-2900	2900	20.8	36.9

Type Type Tipo	Rpm max [min ⁻¹]	QR [l/s]	P2 max [kW]
NC50-315EK/274-2900	2900	16.1	30
NC50-315EK/291-2900	2900	17.8	36.9
NC50-315EK/308-2900	2900	19.5	45.8
NC50-315EK/325-2900	2900	21.6	56
NC50-315EK/342-2900	2900	23.2	67.2
NC65-125EK/120-2900	2900	26.7	6
NC65-125EK/130-2900	2900	27.3	7.7
NC65-125EK/139-2900	2900	27.8	9.6
NC65-160EK/145-2900	2900	20.5	8.9
NC65-160EK/155-2900	2900	24.2	11
NC65-160EC/160-2900	2900	23.3	11.3
NC65-160EK/165-2900	2900	28	13.6
NC65-160EK/174-2900	2900	30.9	15.9
NC65-160EC/175-2900	2900	26.7	15
NC65-200EK/175-2900	2900	24.8	16
NC65-200EK/185-2900	2900	28.8	19.4
NC65-200EC/188-2900	2900	33.3	21.6
NC65-200EK/195-2900	2900	31.5	22.3
NC65-200EC/202-2900	2900	39.1	30
NC65-200EK/205-2900	2900	32.5	26.1
NC65-200EK/214-2900	2900	33.7	29.4
NC65-200EC/215-2900	2900	39.1	37.6
NC65-250EC/212-2900	2900	26.7	21.3
NC65-250EK/225-2900	2900	27.8	31.5
NC65-250EC/232-2900	2900	26.7	31.2
NC65-250EK/235-2900	2900	29.7	35.8
NC65-250EK/245-2900	2900	31.5	40.4
NC65-250EC/249-2900	2900	26.7	36.2
NC65-250EK/255-2900	2900	33.4	45.6
NC65-250EK/264-2900	2900	35	50.5
NC80-200EK/175-2900	2900	41.3	19.4
NC80-200EK/185-2900	2900	44.7	23.7
NC80-200EK/195-2900	2900	43.8	27.5
NC80-200EK/205-2900	2900	46.4	32.5

Type Type Tipo	Rpm max [min ⁻¹]	QR [l/s]	P2 max [kW]
NC80-200EK/214-2900	2900	47.3	38.7
NC80-250EC/207-2900	2900	33.3	19.5
NC80-250EC/226-2900	2900	36.7	25.3
NC80-250EC/238-2900	2900	39.2	38.6
NC80-250EC/250-2900	2900	39.2	44.7
NC80-250EC/264-2900	2900	39.2	54.7
NC100-160EK/165-2900	2900	54.5	22.4
NC100-160EK/174-2900	2900	60.3	26.6
NC100-200EK/170-2900	2900	41.7	16.5
NC100-200EK/184-2900	2900	41.7	20
NC100-200EC/210-2900	2900	41.7	35.4
NC100-200EK/214-2900	2900	72.4	55.9
NC100-200EC/219-2900	2900	46.7	43.3
NC100-250EC/241-2900	2900	53.3	55.2
NC100-250EC/265-2900	2900	53.3	72.8
NC100-315EK/274-2900	2900	60.1	83.5
NC100-315EK/291-2900	2900	65.7	97.9
NC100-315EK/308-2900	2900	70.9	117.7
NC100-315EK/325-2900	2900	77.9	143
NC100-315EK/342-2900	2900	80.6	174.9
NC125-250EK/222-2900	2900	79.5	70.8
NC125-250EK/236-2900	2900	85.2	87.2
NC125-250EK/250-2900	2900	85.3	104
NC125-250EK/264-2900	2900	85.4	125
NC125-250EK/278-2900	2900	87.1	146.8
NC125-315EK/330-2640	2640	70.8	162.3
NC125-400EK/405-2100	2100	70.8	160.7
NC150-315EK/322-1480	1480	133.3	90.3
NC150-400EK/420-2045	2045	125	229.6

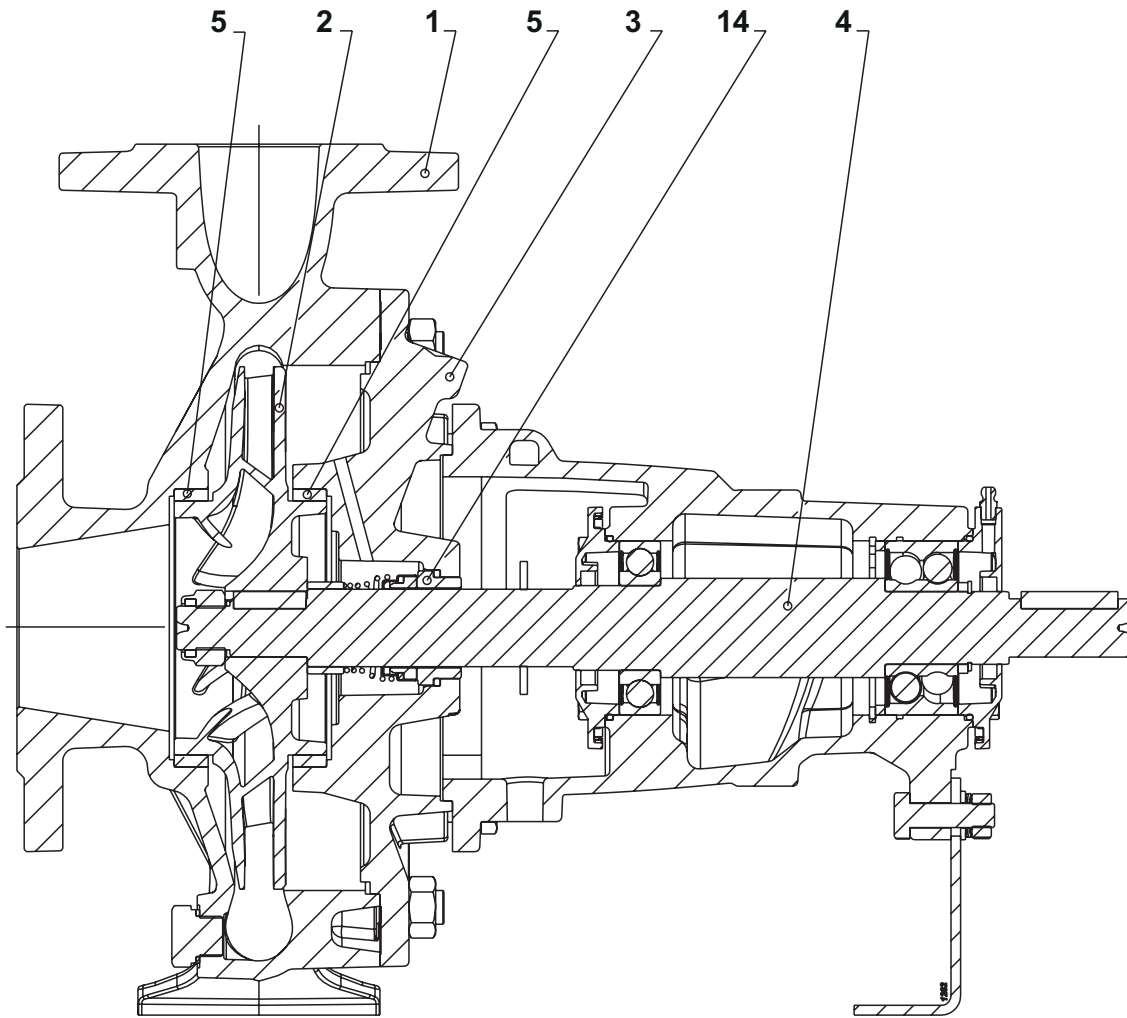

Pos.	Parts	Materials	Nomenclature	Matériaux	Nomenclatura	Materiale
1	Pump casing	Cast iron	Corps de pomp	Fonte grise	Corpo pompa	Ghisa grigia
1	Pump casing	Nodular cast iron	Corps de pomp	Fonte sphéroïdale	Corpo pompa	Ghisa sferoidale
2	Impeller	Bronze/Stainless steel	Roue	Bronze/Acier inox	Girante	Bronzo/Acciaio inox
3	Lantern bracket	Cast iron	Lanterne-support	Fonte grise	Supporto di collegamento	Ghisa grigia
4	Shaft	Stainless steel	Arbre	Acier inox	Albero	Acciaio inox
5	Impeller wear ring	Bronze	Bague d'usure	Bronze	Anello sede girante	Bronzo
14	Mechanical seal	Carbon/Ceramic/rubber	Garniture mécanique	Charbon /Céramique/ caoutchouc	Tenuta meccanica	Carbone/Ceramica/ gomma

Screws and nuts in stainless steel.

Vis et écrous en acier inox.

Viti e dadi in acciaio inox

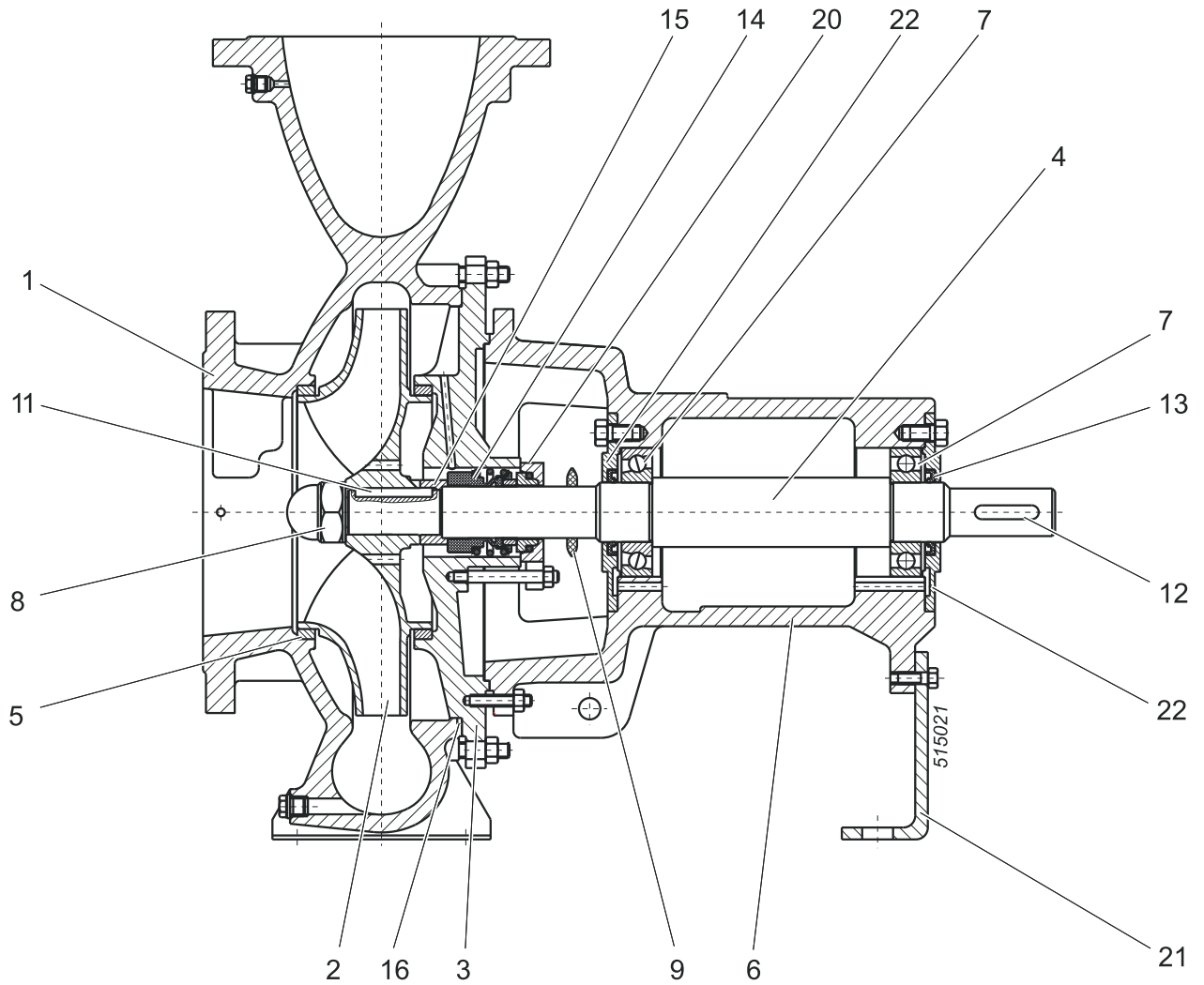

Pos.	Parts	Materials	Nomenclature	Matériaux	Nomenclatura	Materiale
1	Pump casing	Cast iron	Corps de pompe	Fonte grise	Corpo pompa	Ghisa grigia
2	Impeller	Bronze/Stainless steel	Roue	Bronze/Acier inox	Girante	Bronzo/Acciaio inox
3	Lantern bracket	Cast iron	Lanterne-support	Fonte grise	Supporto di collegamento	Ghisa grigia
4	Shaft	Stainless steel	Arbre	Acier inox	Albero	Acciaio inox
5	Impeller wear ring	Bronze	Bague d'usure	Bronze	Anello sede girante	Bronzo
6	Support	Cast iron	Support	Fonte grise	Supporto	Ghisa grigia
7	Bearing	-	Coussinet	-	Cuscinetto	-
8	Nut	Stainless steel	Ecrou	Acier inox	Dado	Acciaio inox
9	Water retainer ring	Nitrile rubber	Bague déflecteur	Caoutchouc nitrile	Anello para-acqua	Gomma nitrilica
11	Feather key	Stainless steel	Languette	Acier inox	Linguetta	Acciaio inox
12	Feather key 2	Steel	Languette 2	Acier	Linguetta 2	Acciaio
13	Seal ring	Nitrile rubber	Bague d'étanchéité	Caoutchouc nitrile	Anello di tenuta	Gomma nitrilica
14	Mechanical seal	-	Garniture mécanique	-	Tenuta meccanica	-
15	Spacer sleeve	Stainless steel	Entretoise	Acier inox	Distanziale	Acciaio inox
16	OR Seal ring	Nitrile rubber	Bague d'étanchéité OR	Caoutchouc nitrile	Anello di tenuta OR	Gomma nitrilica
20	Cover mechanical seal	Cast iron	Couvercle garniture mécanique	Fonte grise	Coperchio tenuta meccanica	Ghisa grigia
21	Duck foot pedestal	Steel	Pied de soutien	Acier	Piede di sostegno	Acciaio
22	Cover bearing	Cast iron	Couvercle palier	Fonte grise	Coperchio cuscinetto	Ghisa grigia

Screws and nuts in stainless steel.

Vis et écrous en acier inox.

Viti e dadi in acciaio inox

Operating data
 Caracteristiques de fonctionnement
 Caratteristiche di funzionamento

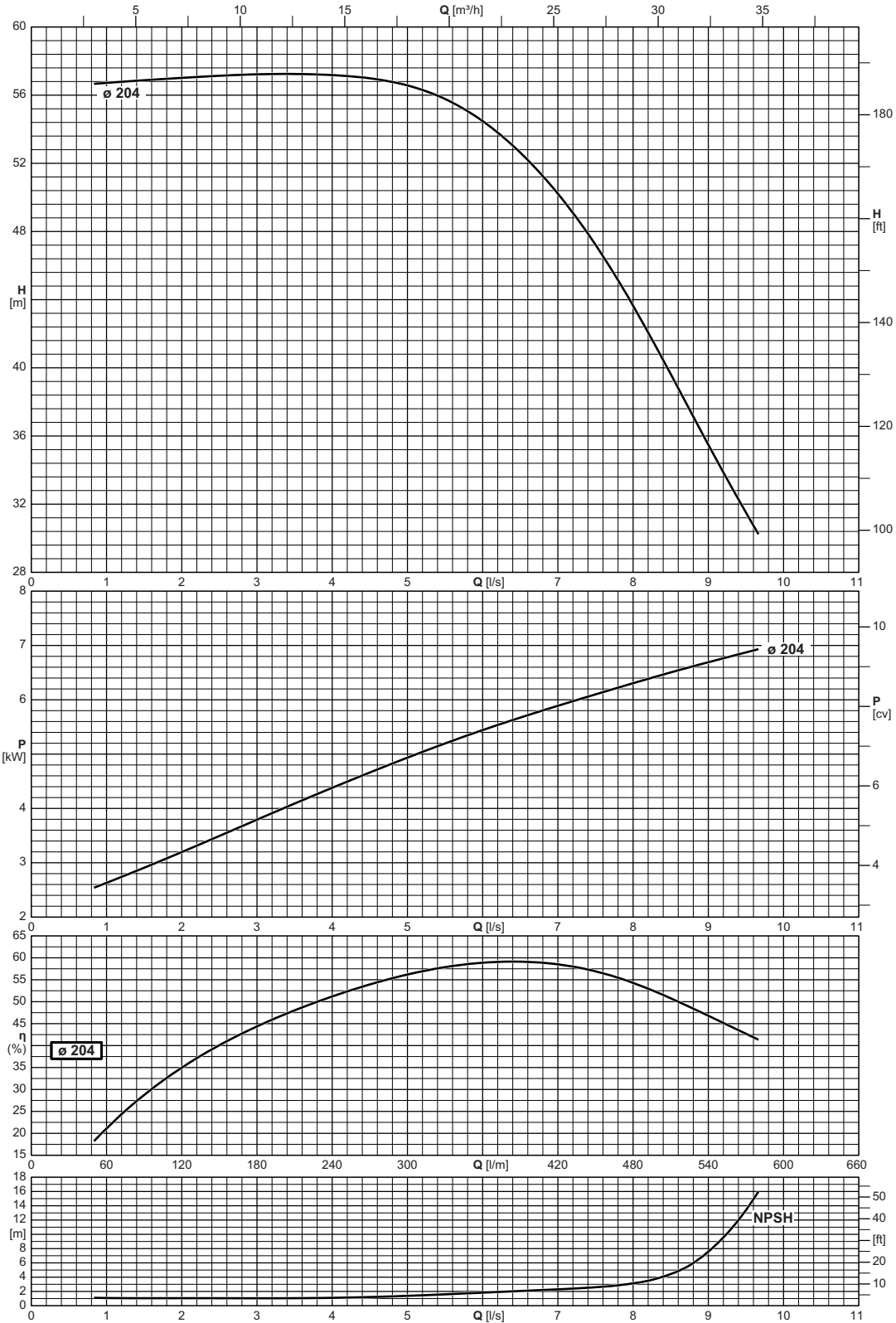

Type Type Tipo	Inlet maximum pressure Pression maximale en aspiration Pressione massima in aspirazione
NC32-200EC	[bar] 10

NC 32-250EK

2900 n [min⁻¹]



Operating data
Caracteristiques de fonctionnement
Caratteristiche di funzionamento

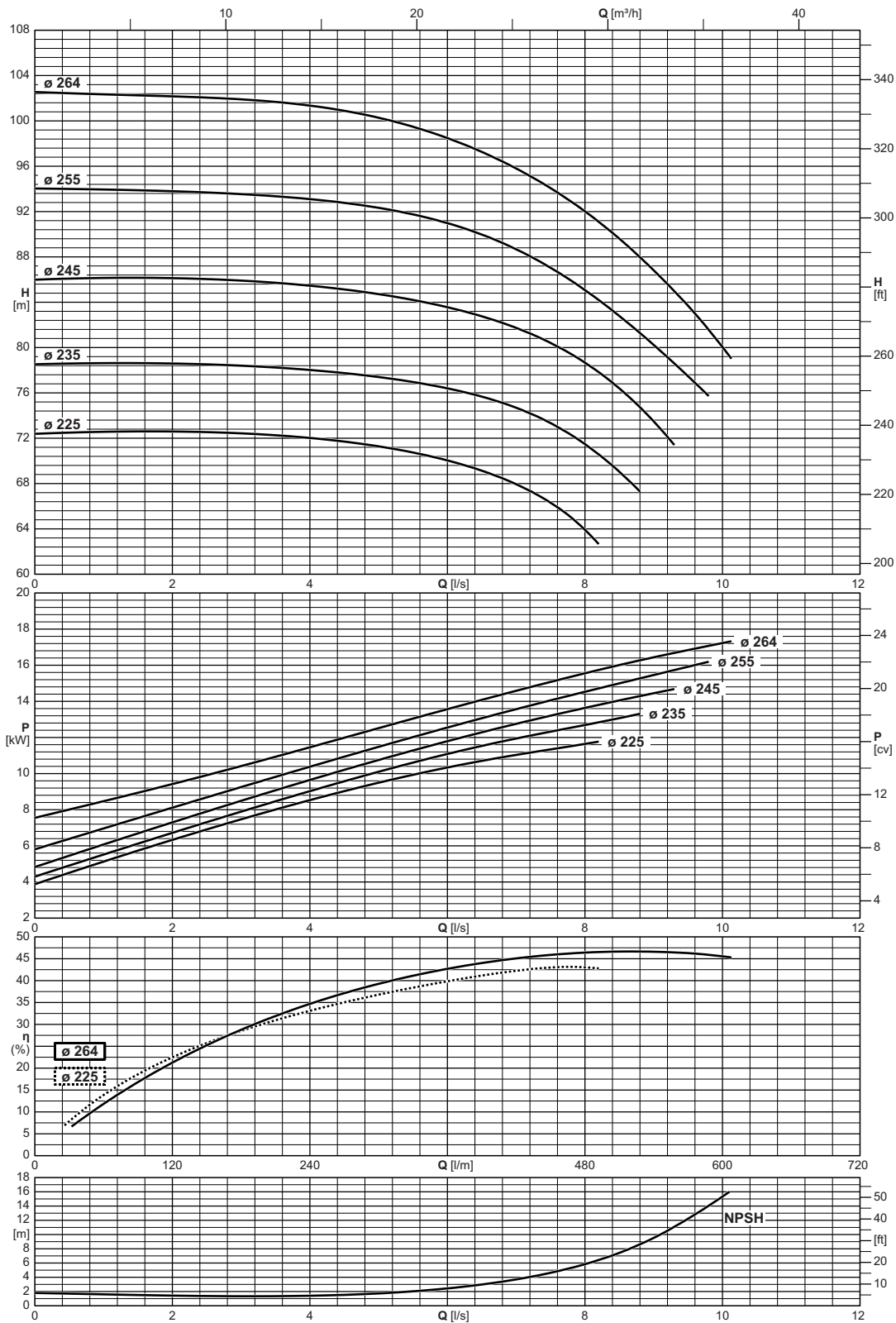

Type Type Tipo	Inlet maximum pressure Pression maximale en aspiration Pressione massima in aspirazione
NC32-250EK	[bar]

Operating data
 Caracteristiques de fonctionnement
 Caratteristiche di funzionamento

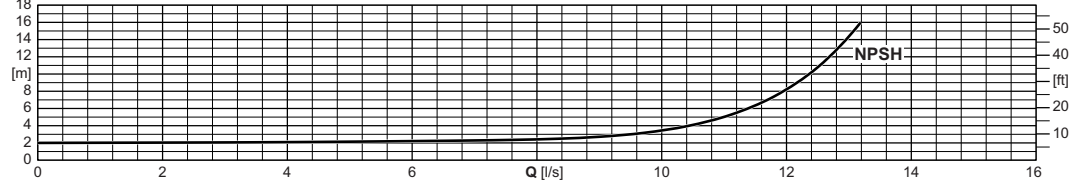
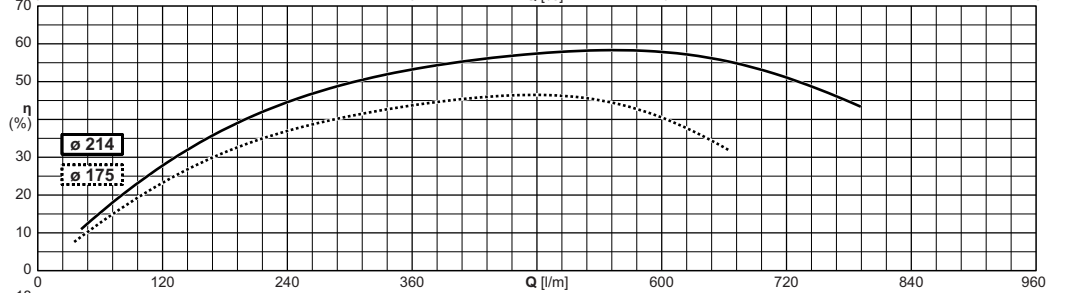
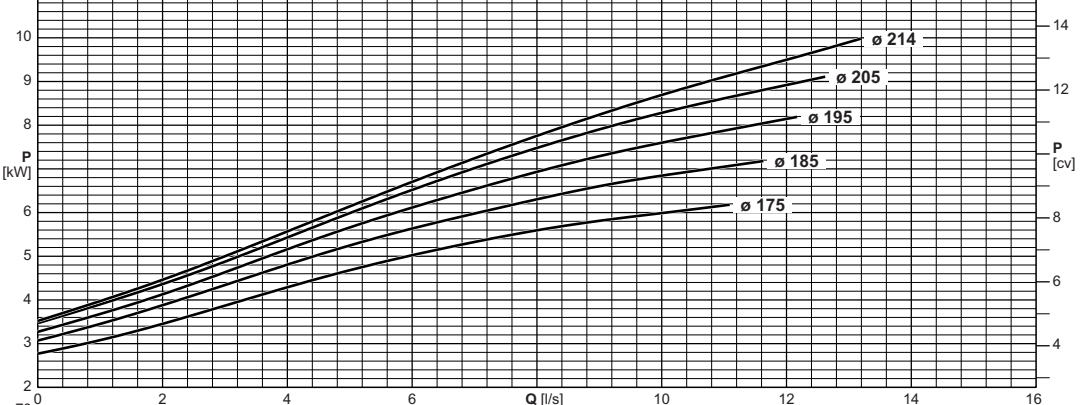
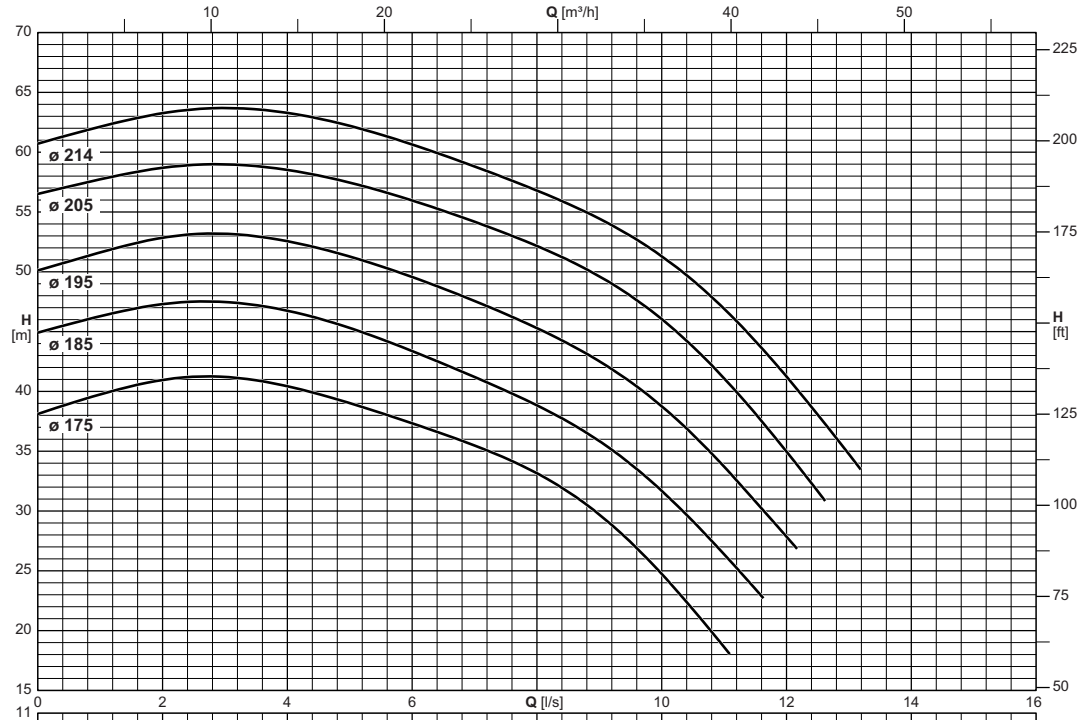

Type Type Tipo	Inlet maximum pressure Pression maximale en aspiration Pressione massima in aspirazione
NC40-200EK	[bar] 2

NC 40-250EC

2900 n [min⁻¹]



Operating data
Caracteristiques de fonctionnement
Caratteristiche di funzionamento

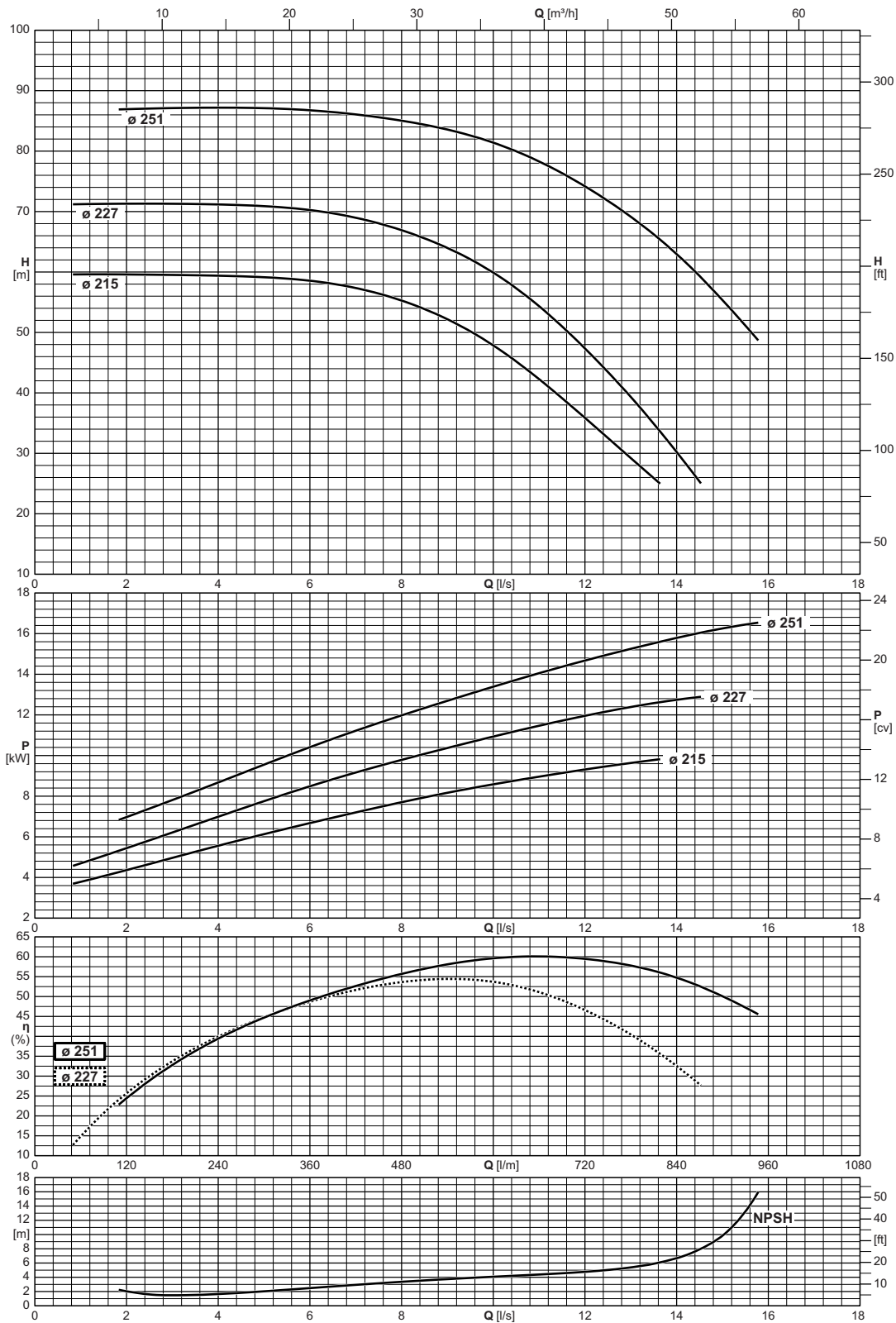

Type Type Tipo	Inlet maximum pressure Pression maximale en aspiration Pressione massima in aspirazione
NC40-250EC	[bar]
	10

Operating data
 Caracteristiques de fonctionnement
 Caratteristiche di funzionamento

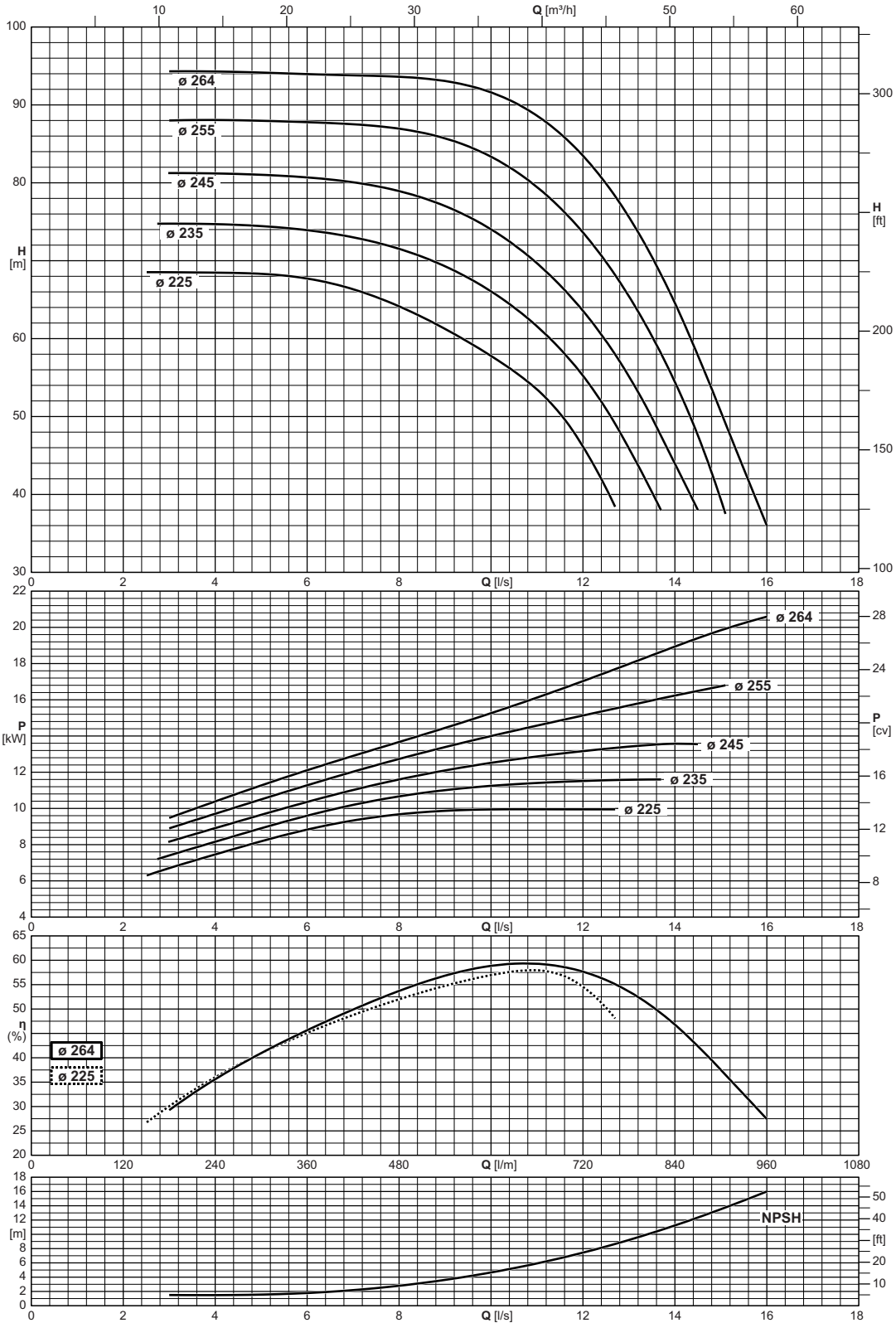

Type Type Tipo	Inlet maximum pressure Pression maximale en aspiration Pressione massima in aspirazione
NC40-250EK	[bar]

NC 50-125EK

2900 n [min⁻¹]



Operating data
 Caracteristiques de fonctionnement
 Caratteristiche di funzionamento

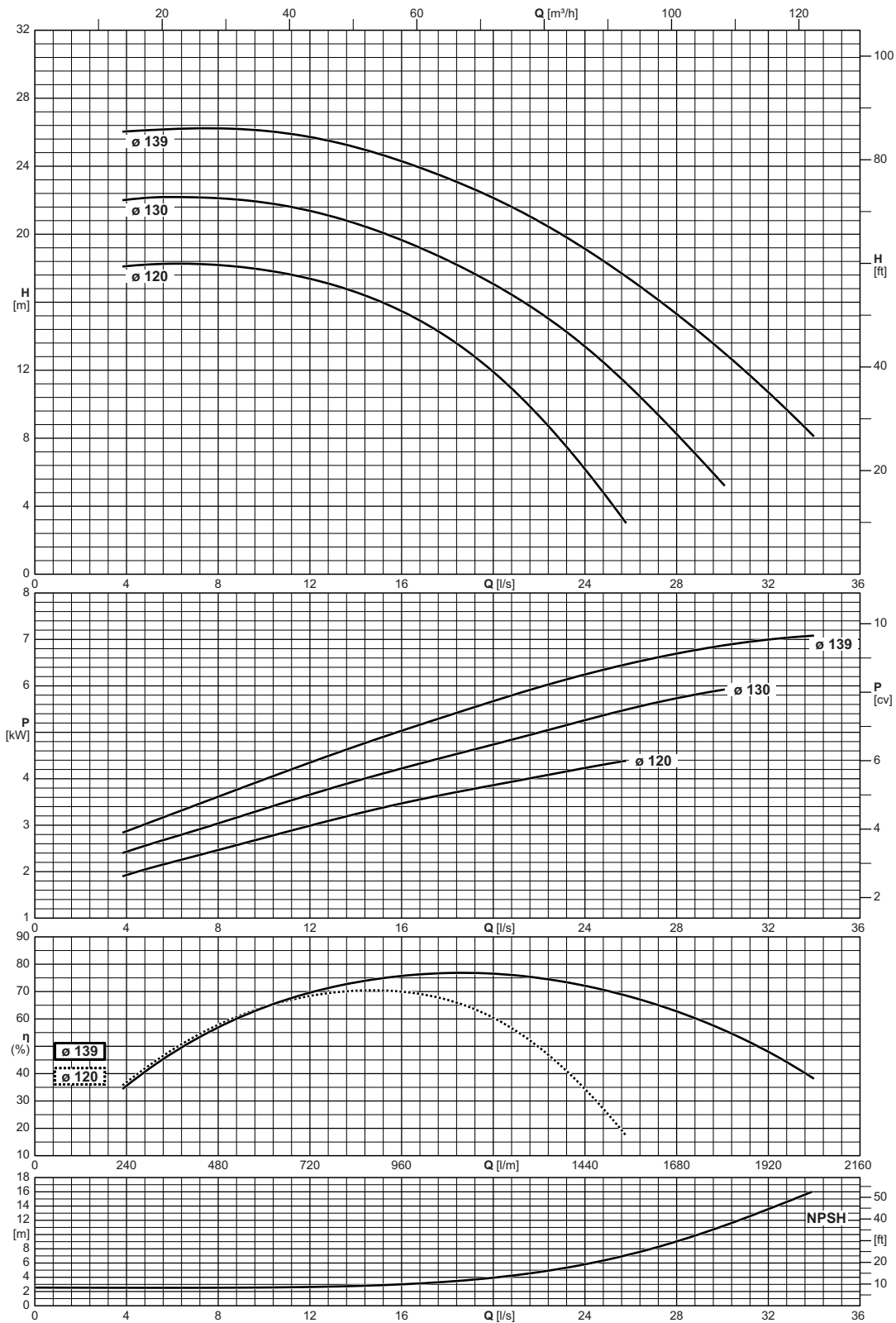

Type Type Tipo	Inlet maximum pressure Pression maximale en aspiration Pressione massima in aspirazione
NC50-125EK	[bar] 6

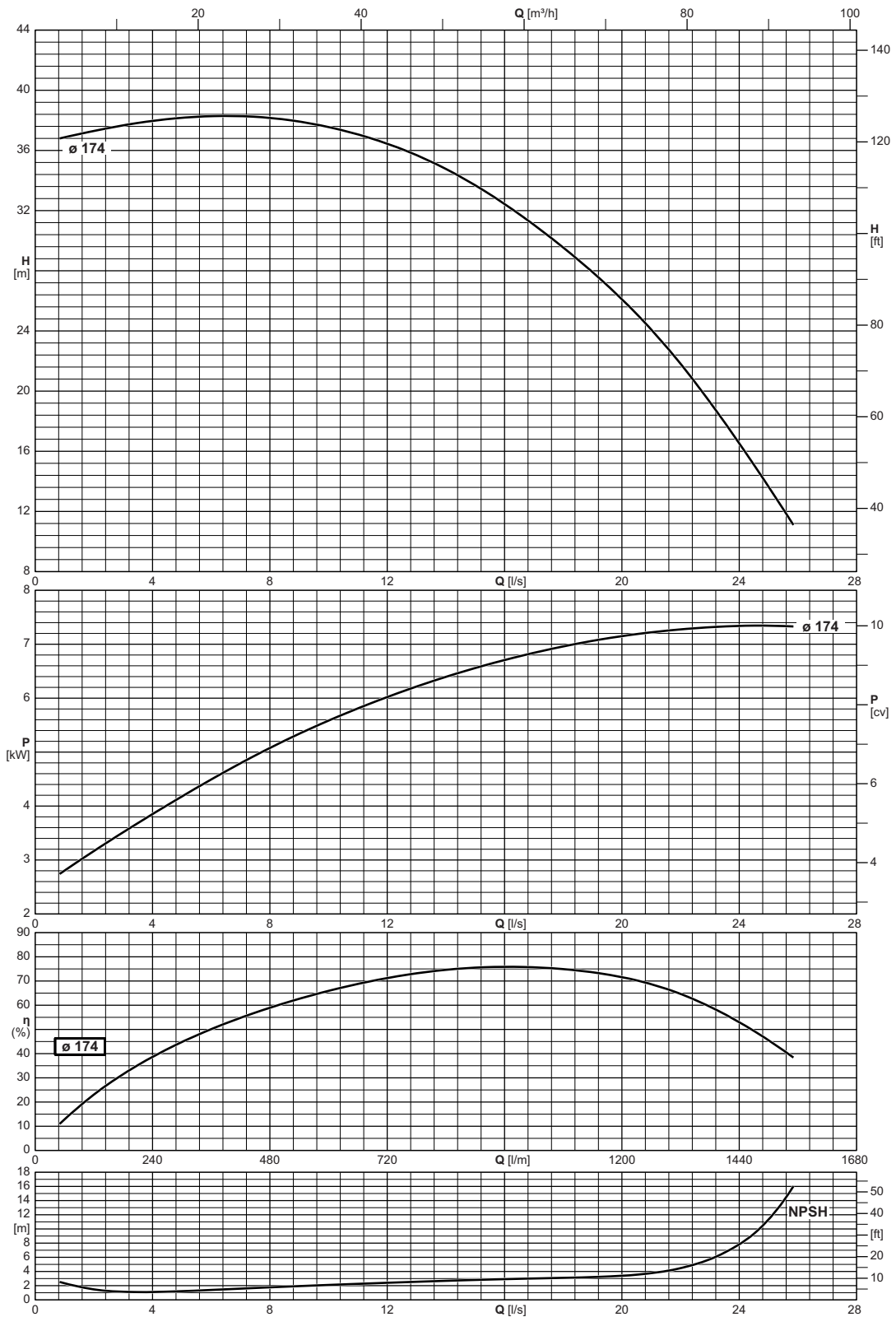

Type Type Tipo	Inlet maximum pressure Pression maximale en aspiration Pressione massima in aspirazione
	[bar]
NC50-160EC	16

NC 50-160EK

2900 n [min⁻¹]



Operating data
 Caracteristiques de fonctionnement
 Caratteristiche di funzionamento

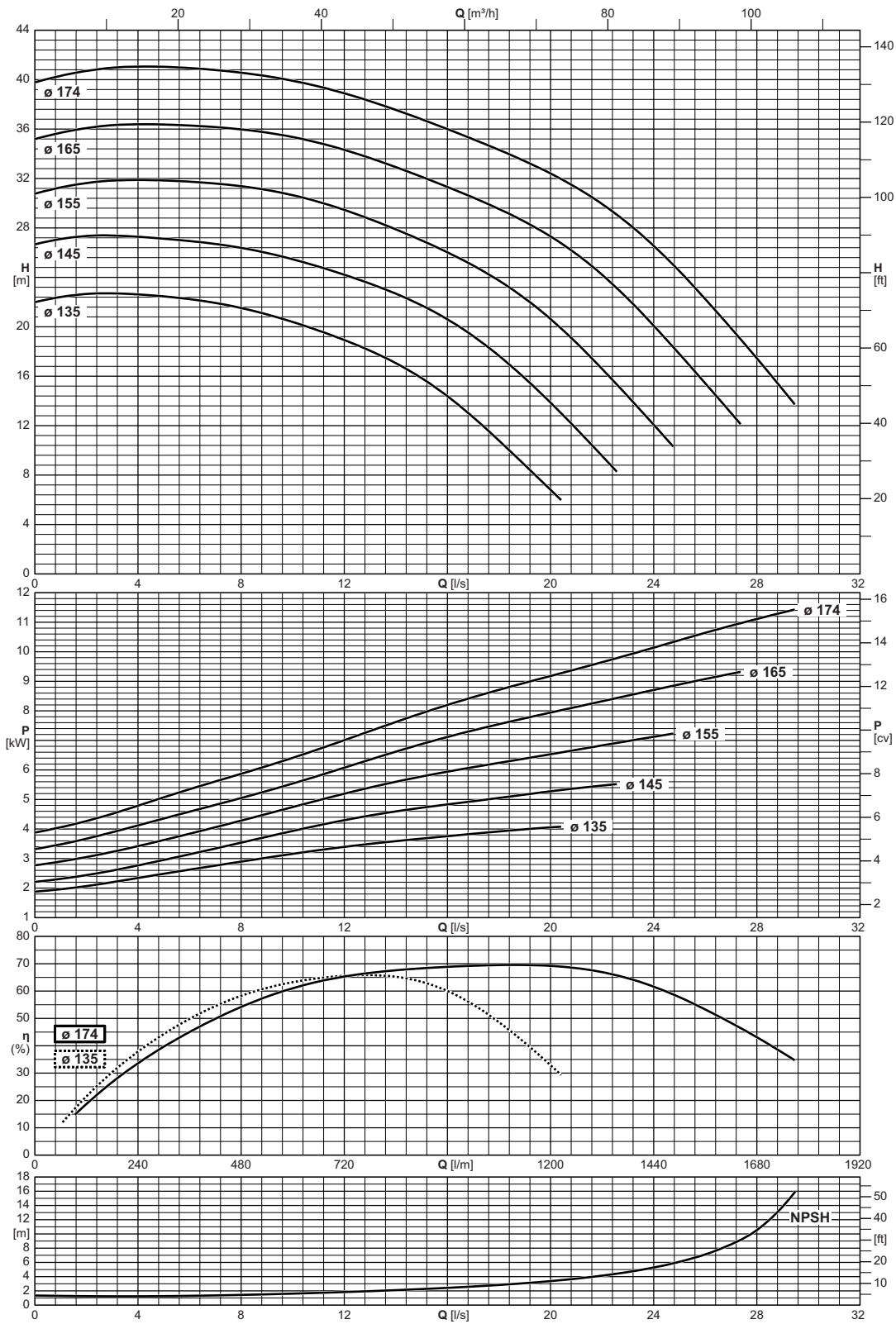

Type Type Tipo	Inlet maximum pressure Pression maximale en aspiration Pressione massima in aspirazione
NC50-160EK	[bar] 4

Operating data
 Caracteristiques de fonctionnement
 Caratteristiche di funzionamento

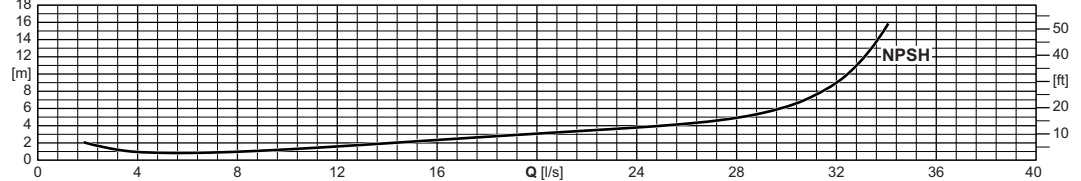
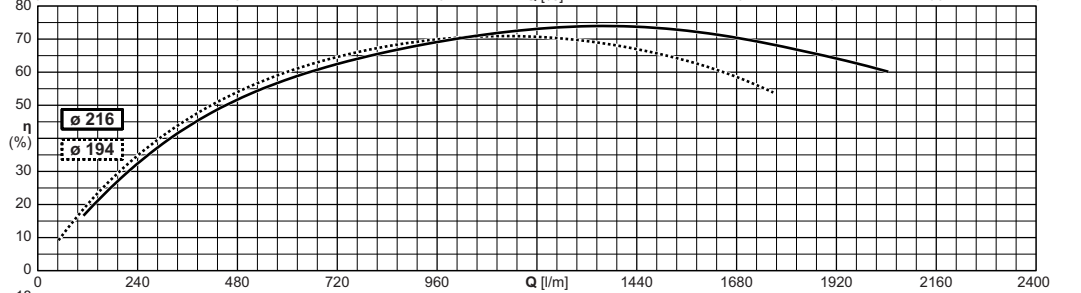
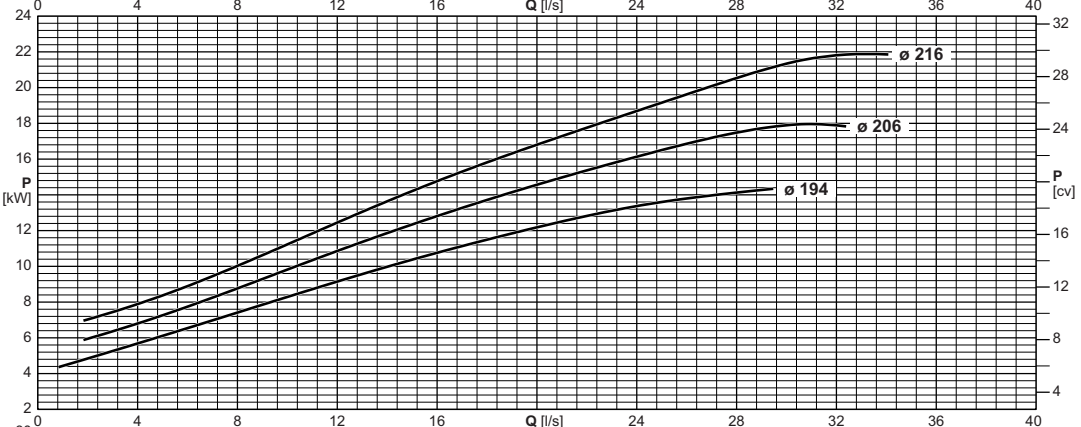
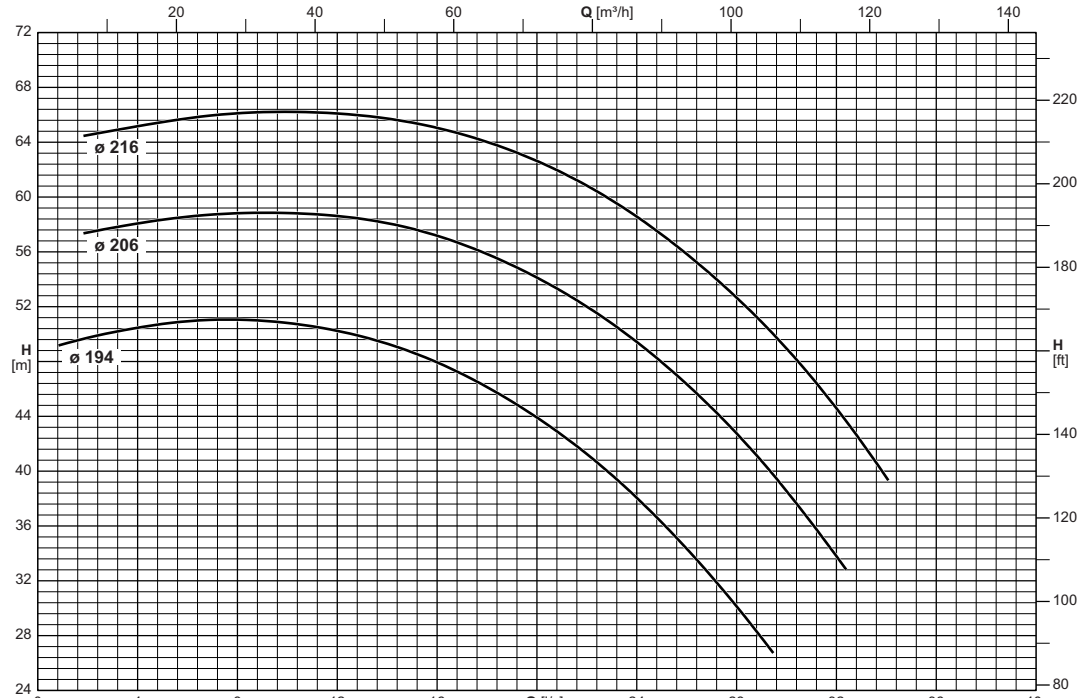

Type Type Tipo	Inlet maximum pressure Pression maximale en aspiration Pressione massima in aspirazione
NC50-200EC	[bar] 10

NC 50-250EC

2900 n [min⁻¹]



Operating data
Caracteristiques de fonctionnement
Caratteristiche di funzionamento

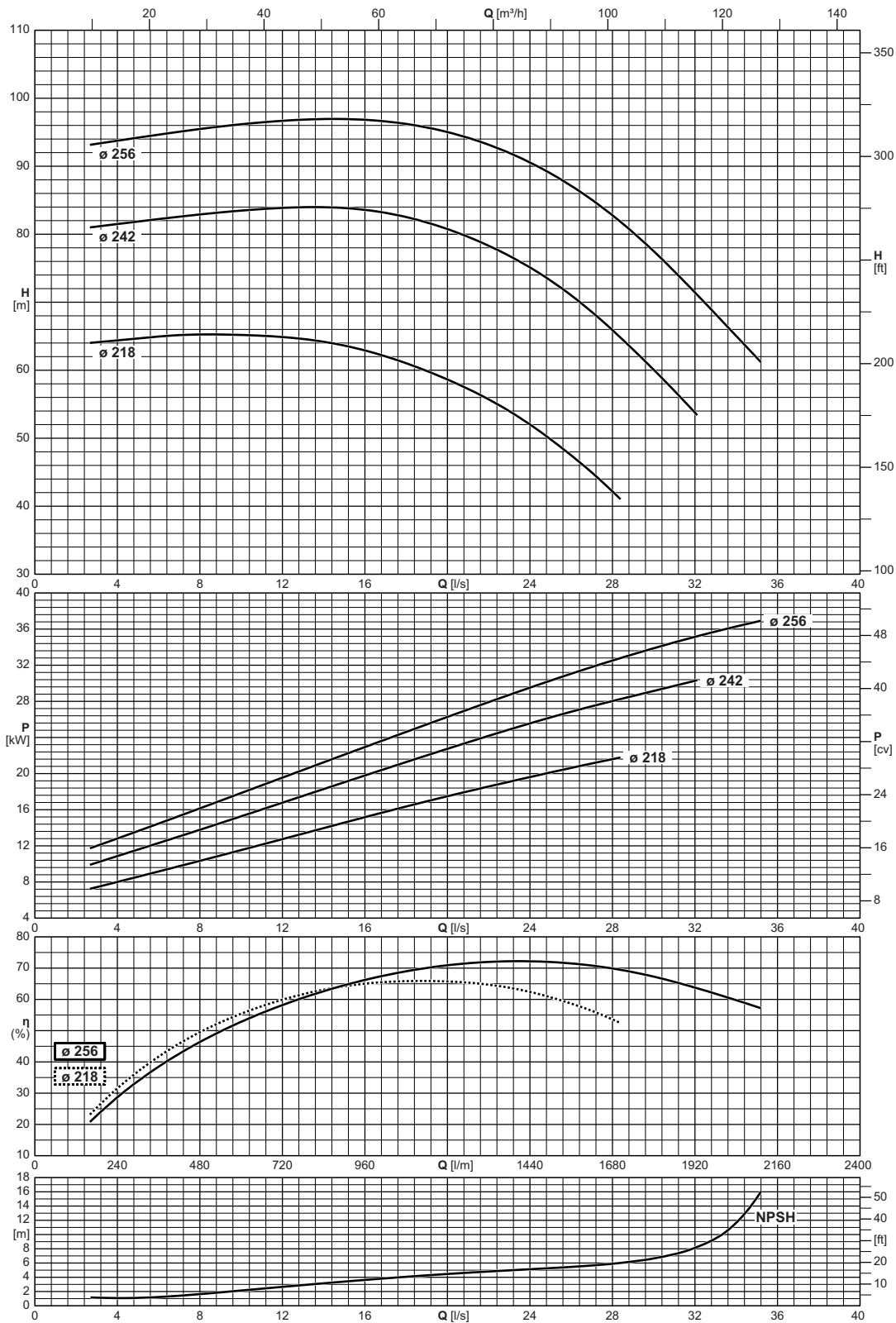

Type Type Tipo	Inlet maximum pressure Pression maximale en aspiration Pressione massima in aspirazione
NC50-250EC	[bar] 10

Operating data
 Caracteristiques de fonctionnement
 Caratteristiche di funzionamento

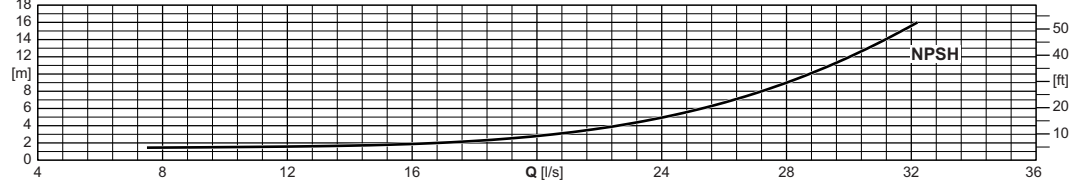
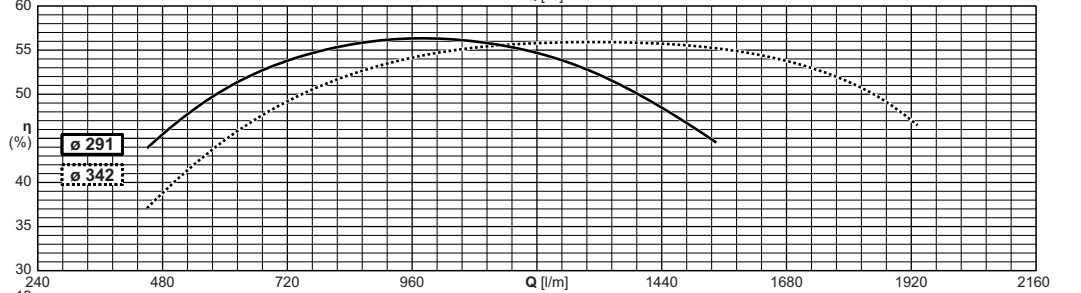
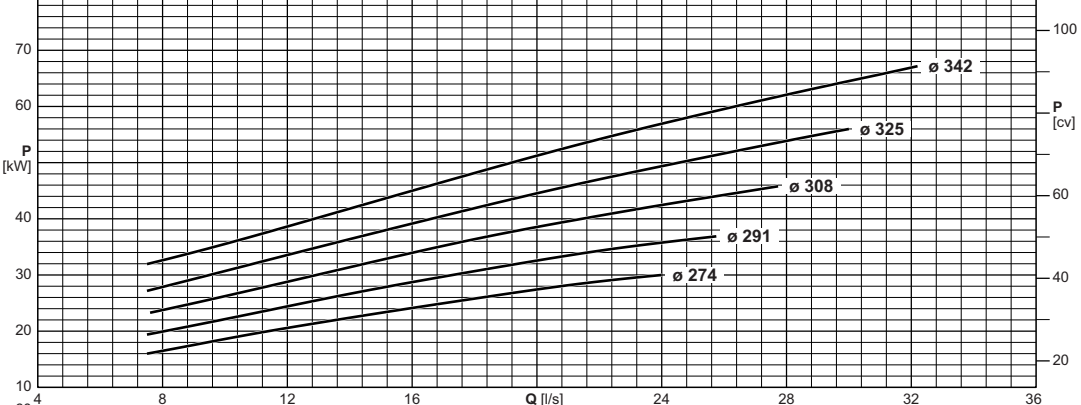
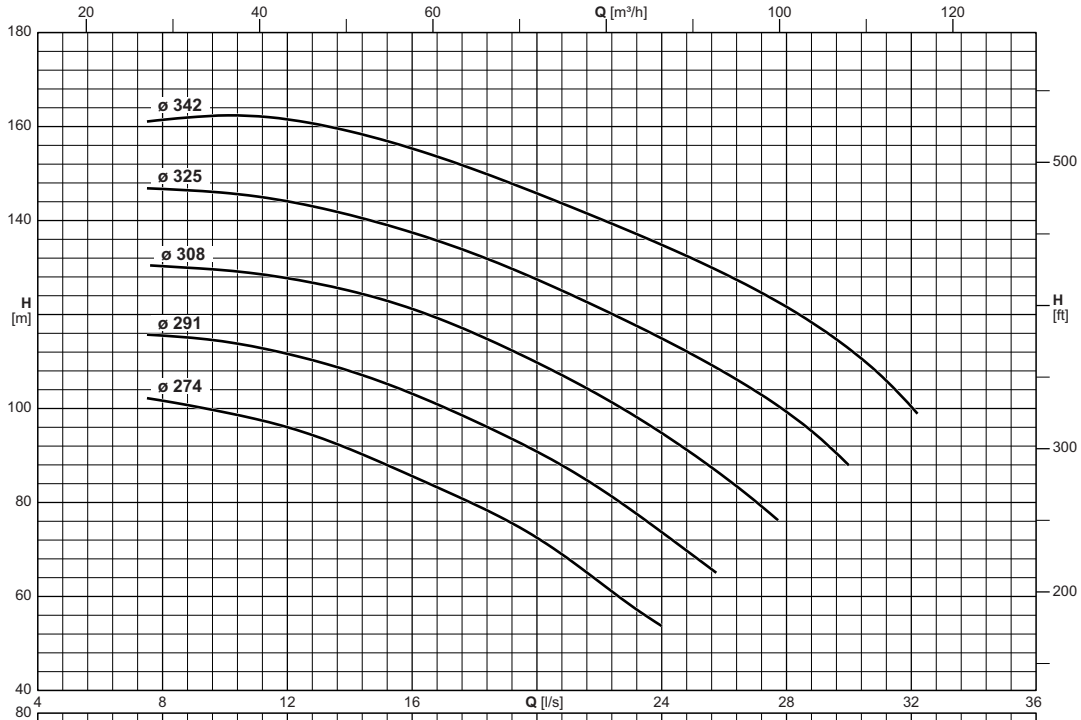

Type Type Tipo	Inlet maximum pressure Pression maximale en aspiration Pressione massima in aspirazione
NC50-315EK	[bar] 8

NC 65-125EK

2900 n [min⁻¹]



Operating data
 Caracteristiques de fonctionnement
 Caratteristiche di funzionamento

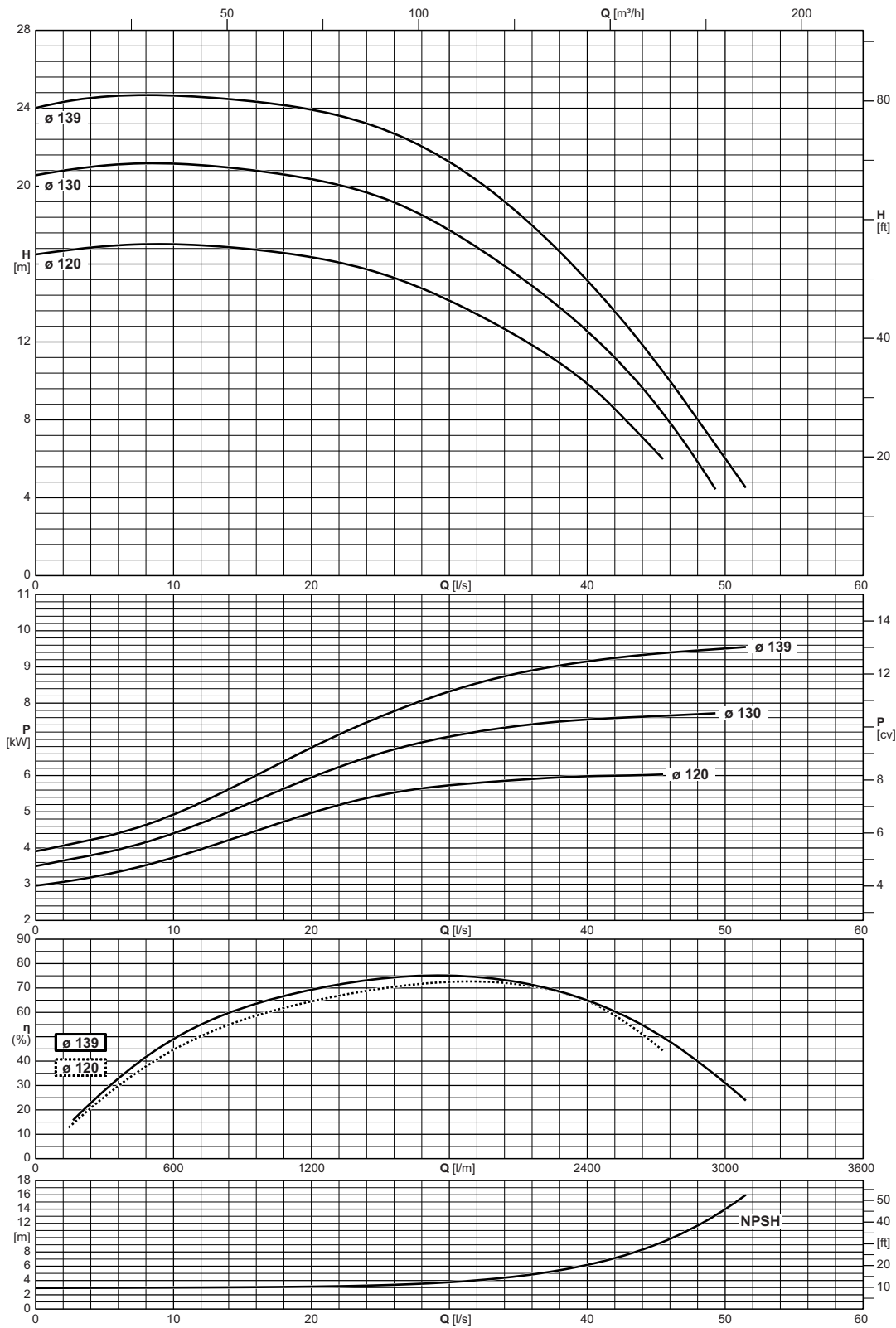

Type Type Tipo	Inlet maximum pressure Pression maximale en aspiration Pressione massima in aspirazione
NC65-125EK	[bar] 6

Operating data
 Caracteristiques de fonctionnement
 Caratteristiche di funzionamento

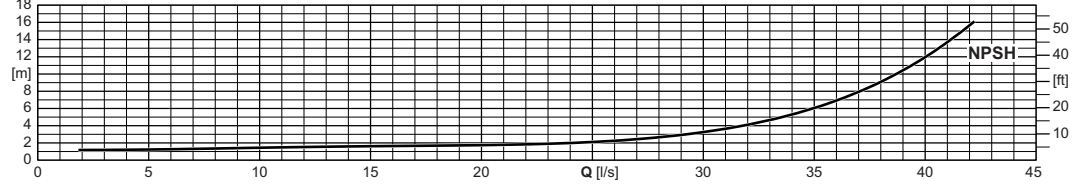
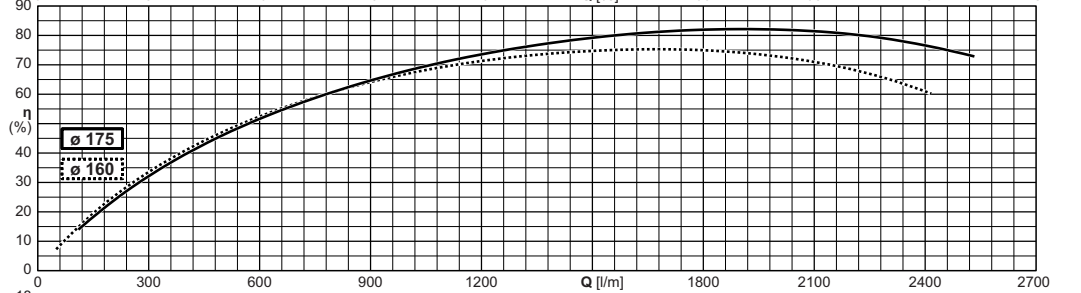
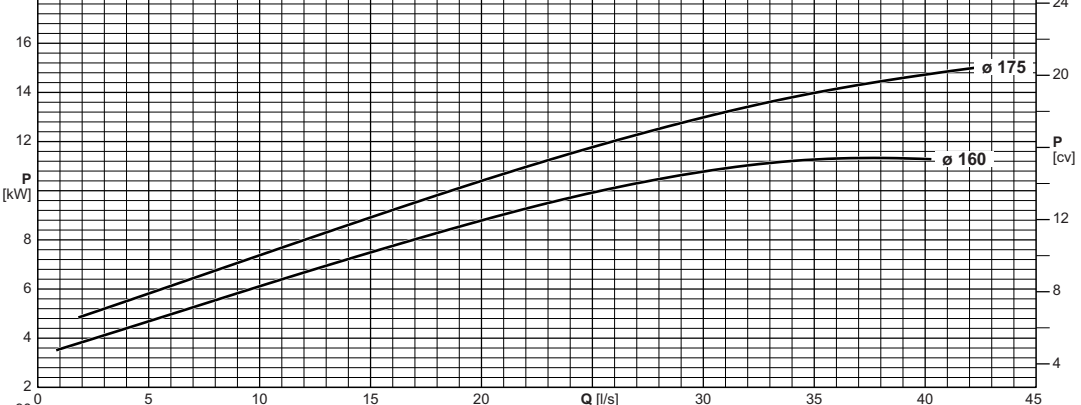
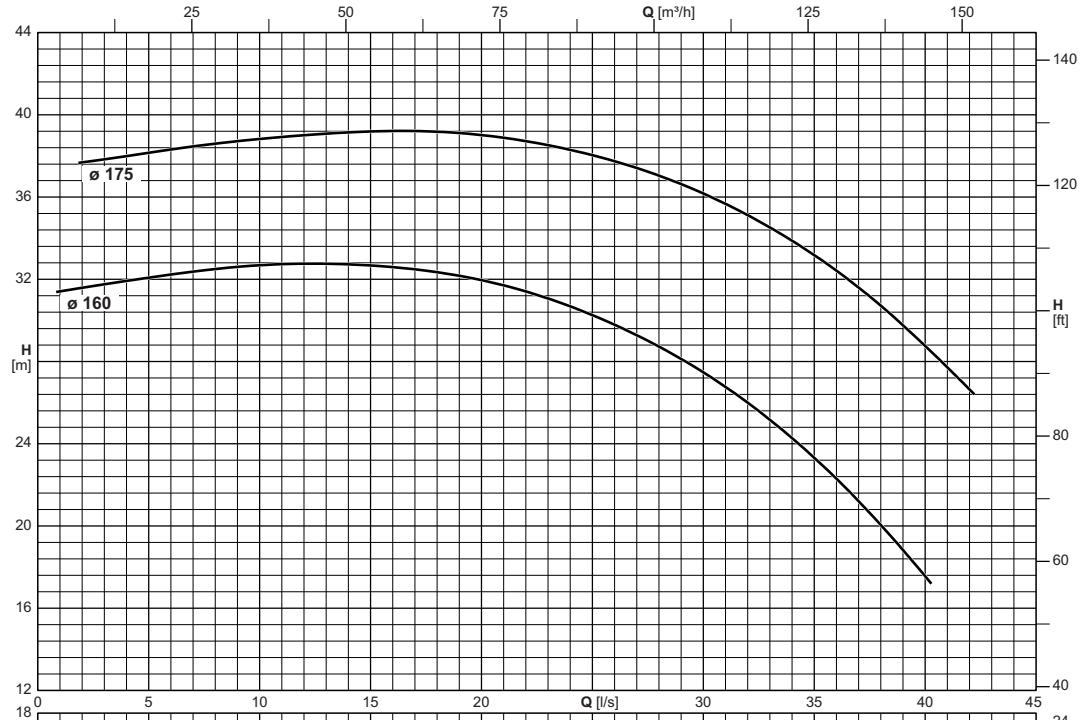

Type Type Tipo	Inlet maximum pressure Pression maximale en aspiration Pressione massima in aspirazione
NC65-160EC	[bar] 16

NC 65-160EK

2900 n [min⁻¹]



Operating data
 Caracteristiques de fonctionnement
 Caratteristiche di funzionamento

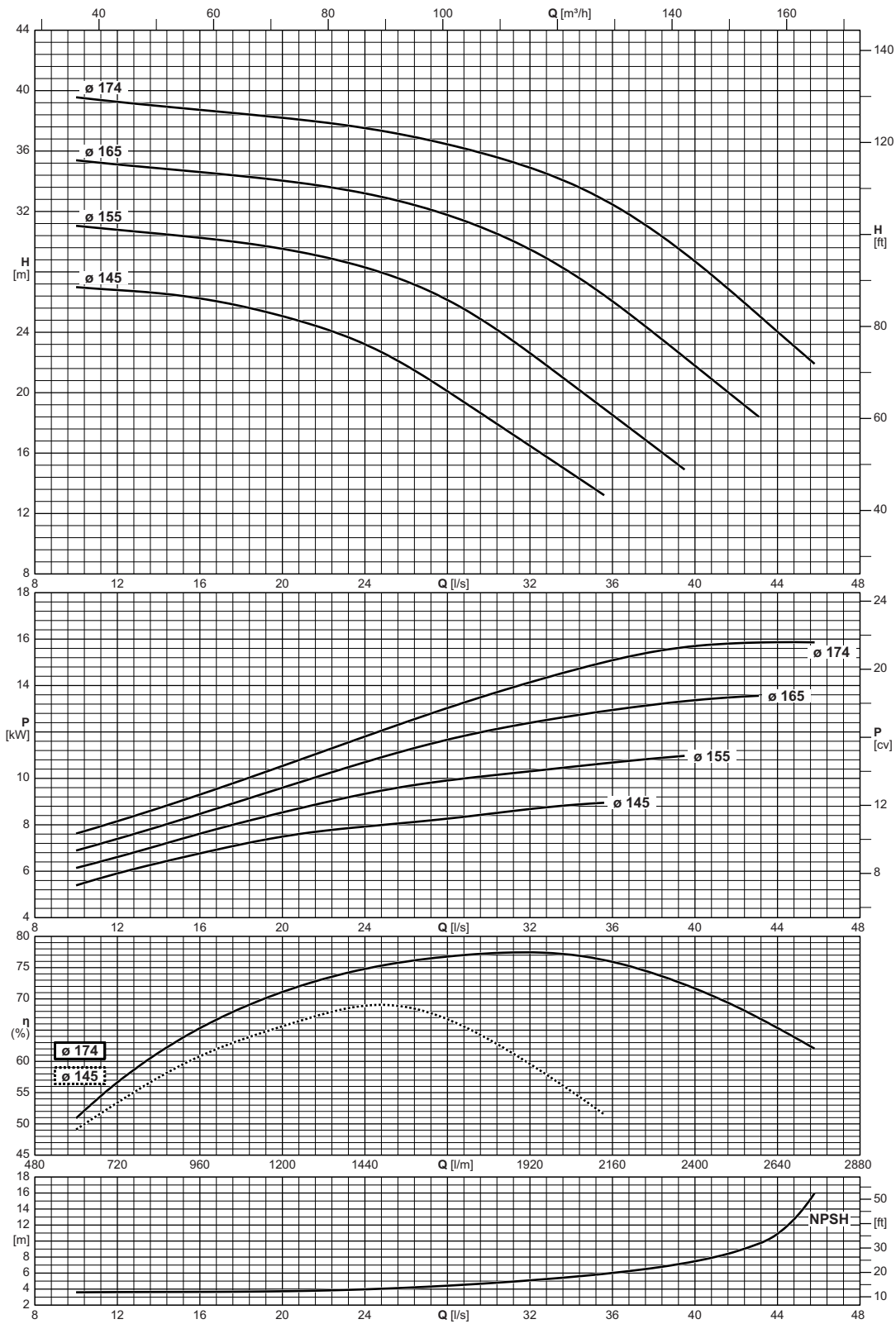

Type Type Tipo	Inlet maximum pressure Pression maximale en aspiration Pressione massima in aspirazione
NC65-160EK	[bar]
	5

Operating data
 Caracteristiques de fonctionnement
 Caratteristiche di funzionamento

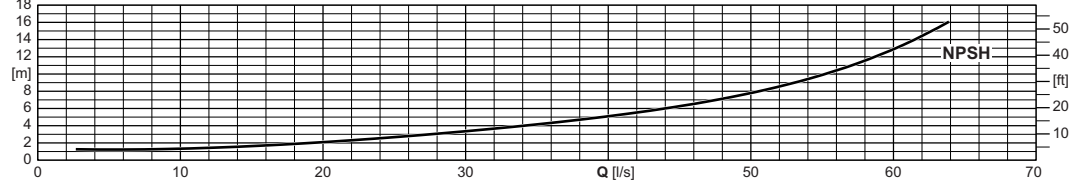
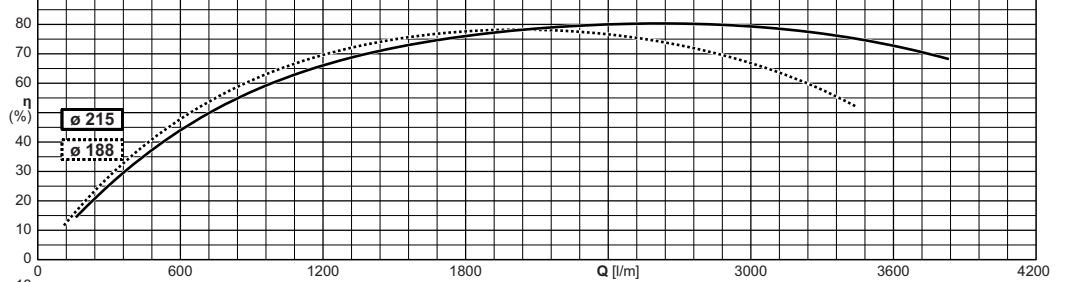
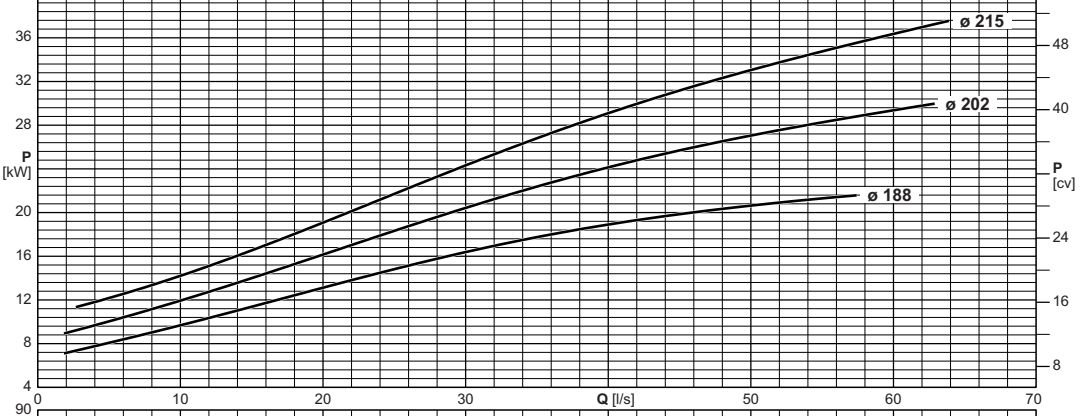
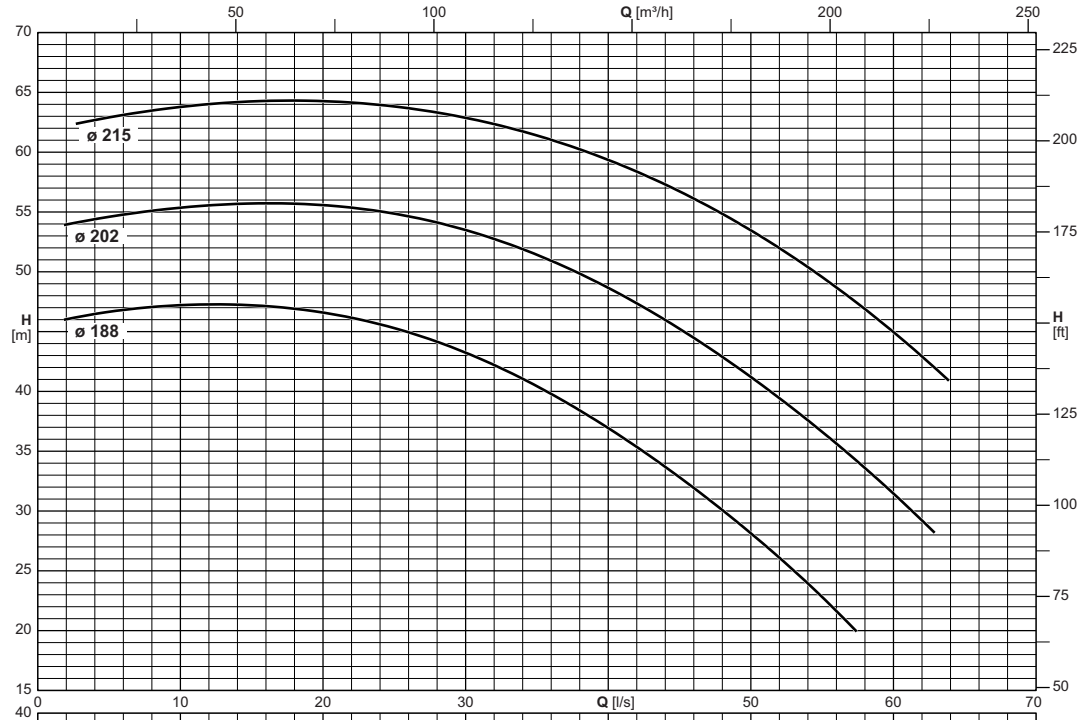

Type Type Tipo	Inlet maximum pressure Pression maximale en aspiration Pressione massima in aspirazione
NC65-200EC	[bar] 16

NC 65-200EK

2900 n [min⁻¹]



Operating data
Caracteristiques de fonctionnement
Caratteristiche di funzionamento

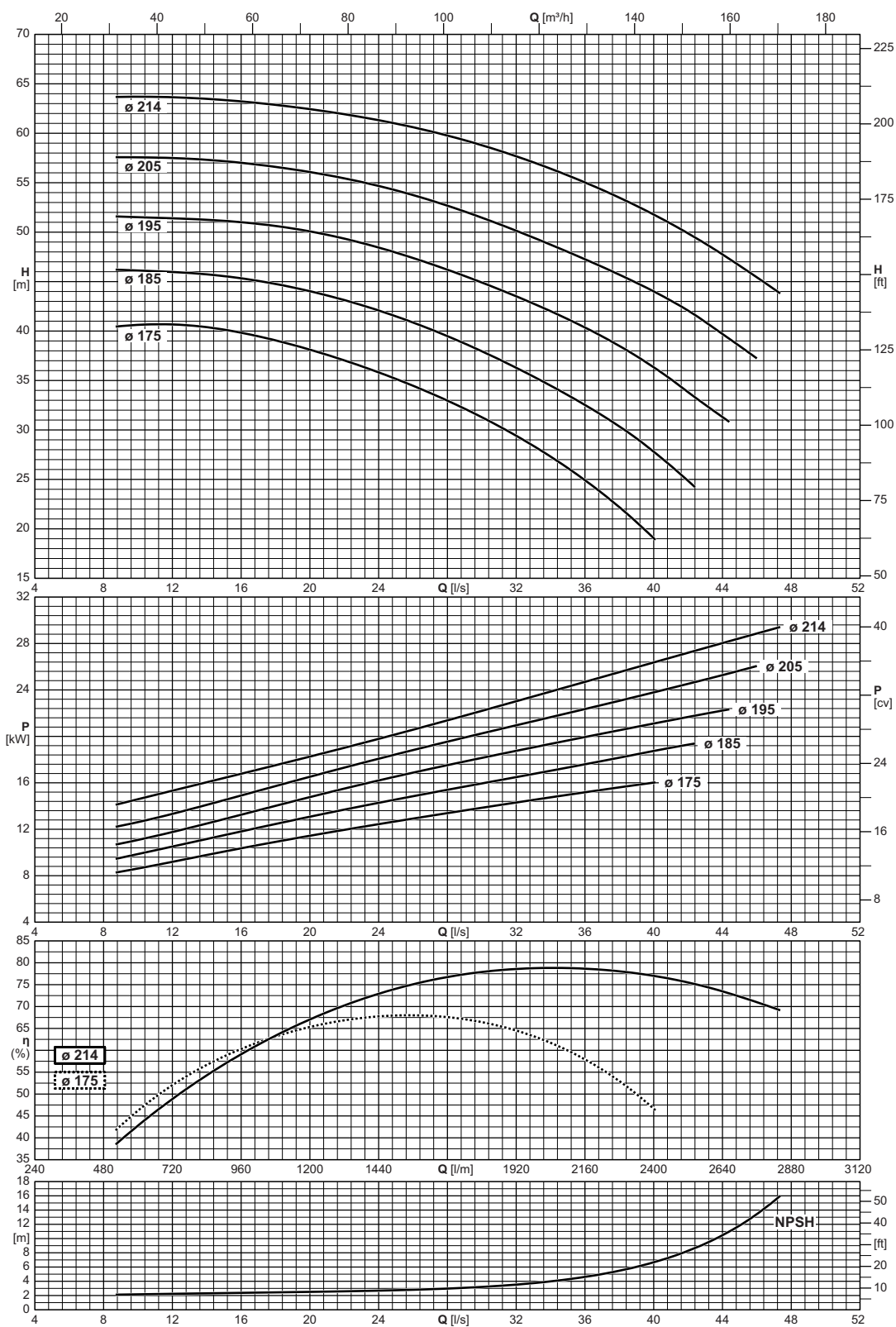

Type Type Tipo	Inlet maximum pressure Pression maximale en aspiration Pressione massima in aspirazione
	[bar] 2
NC65-200EK	

Operating data
 Caracteristiques de fonctionnement
 Caratteristiche di funzionamento

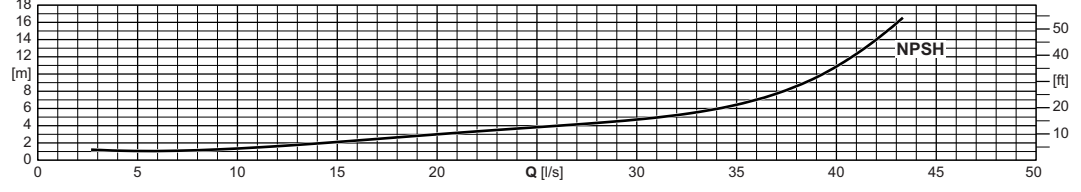
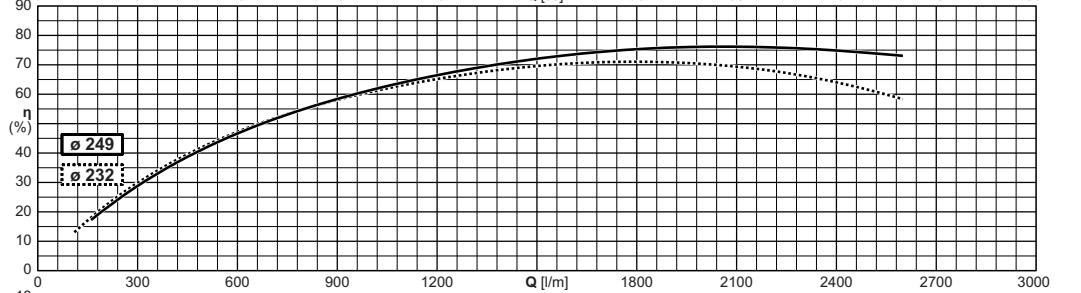
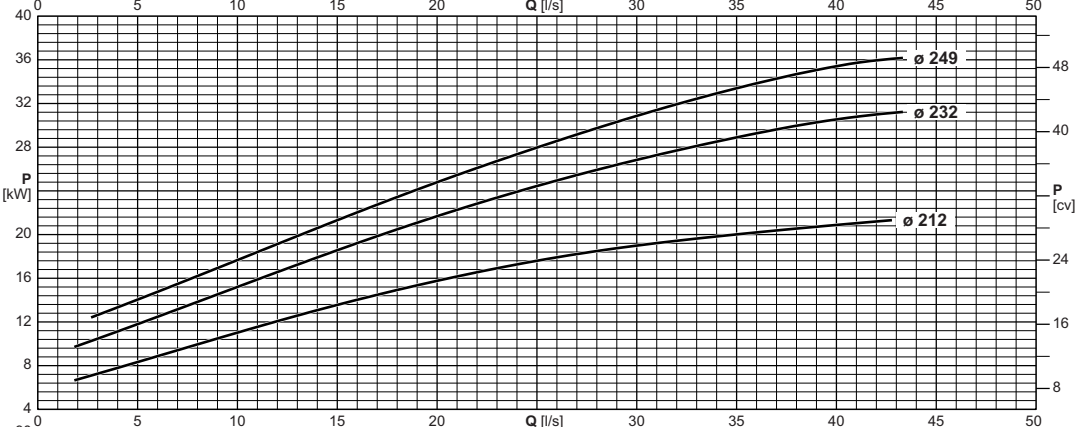
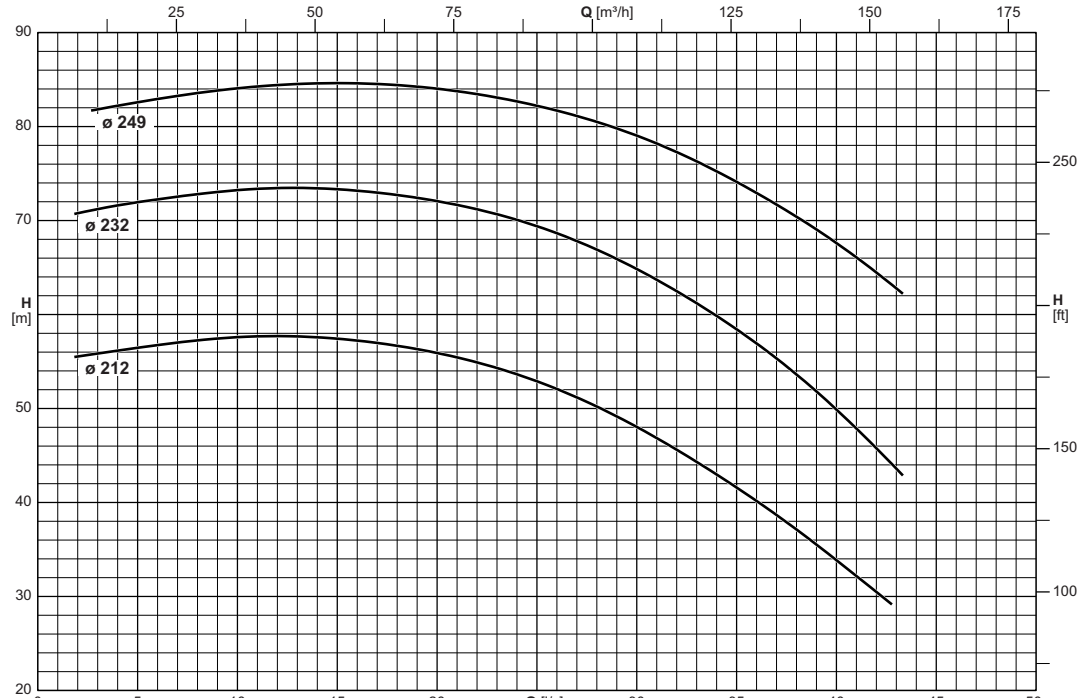

Type Type Tipo	Inlet maximum pressure Pression maximale en aspiration Pressione massima in aspirazione
NC65-250EC	[bar] 16

NC 65-250EK

2900 n [min⁻¹]



Operating data
 Caracteristiques de fonctionnement
 Caratteristiche di funzionamento

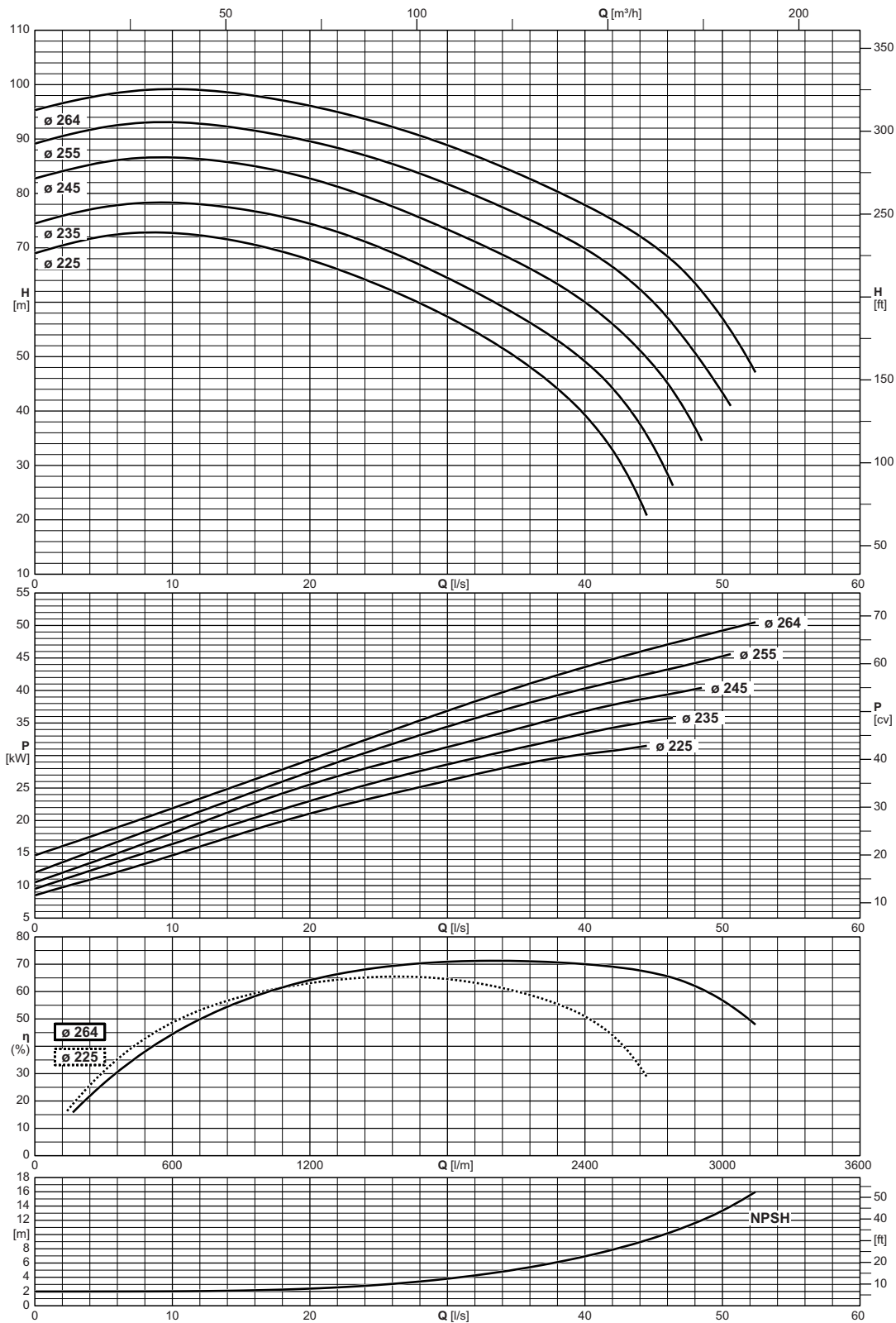

Type Type Tipo	Inlet maximum pressure Pression maximale en aspiration Pressione massima in aspirazione
NC65-250EK	[bar]

Operating data
 Caracteristiques de fonctionnement
 Caratteristiche di funzionamento

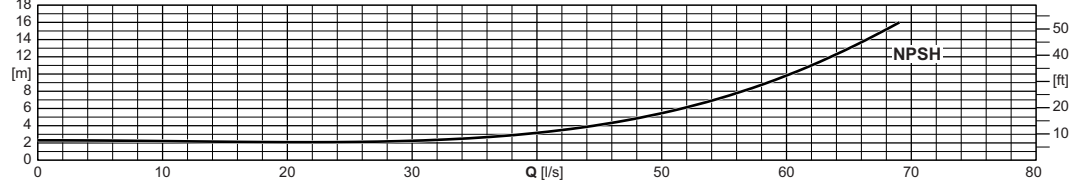
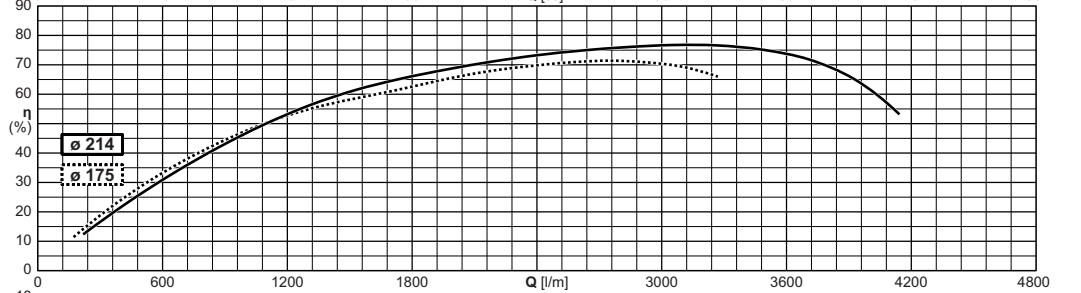
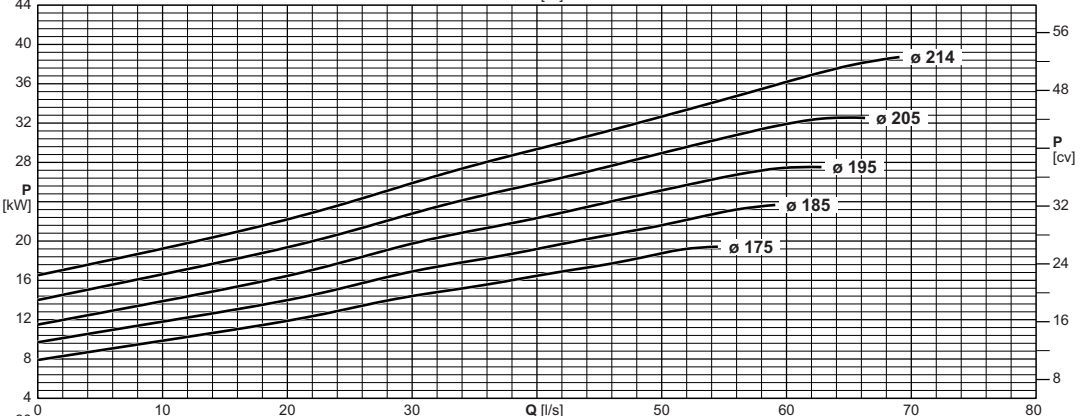
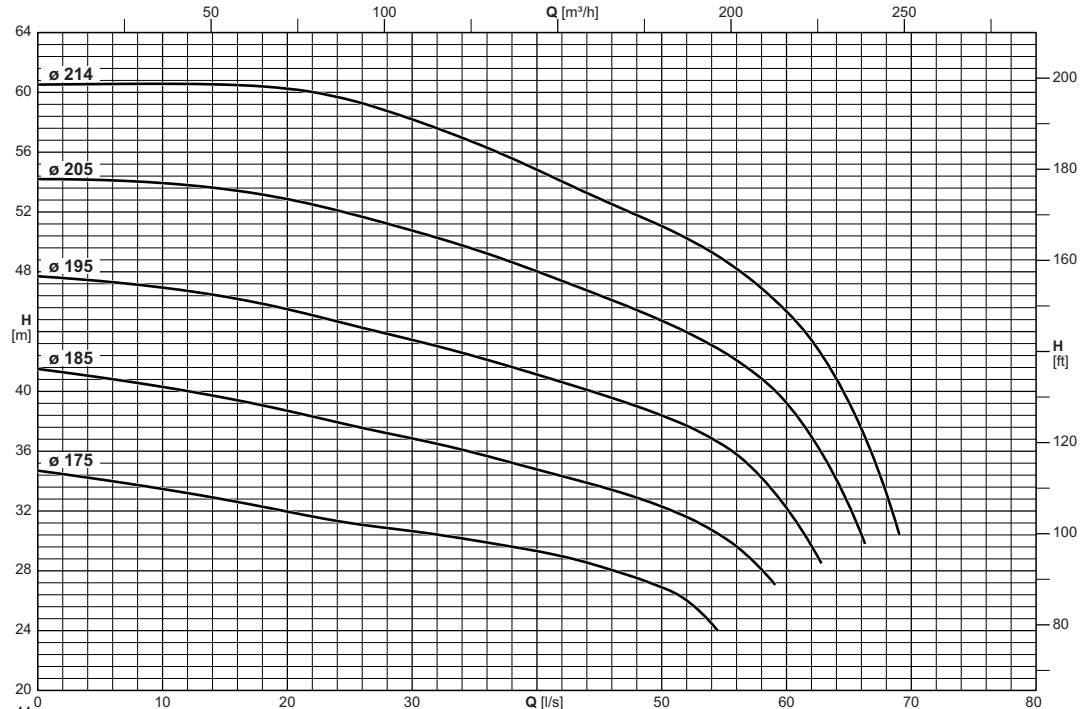

Type Type Tipo	Inlet maximum pressure Pression maximale en aspiration Pressione massima in aspirazione
NC80-200EK	[bar] 2

NC 80-250EC

2900 n [min⁻¹]



Operating data
Caracteristiques de fonctionnement
Caratteristiche di funzionamento

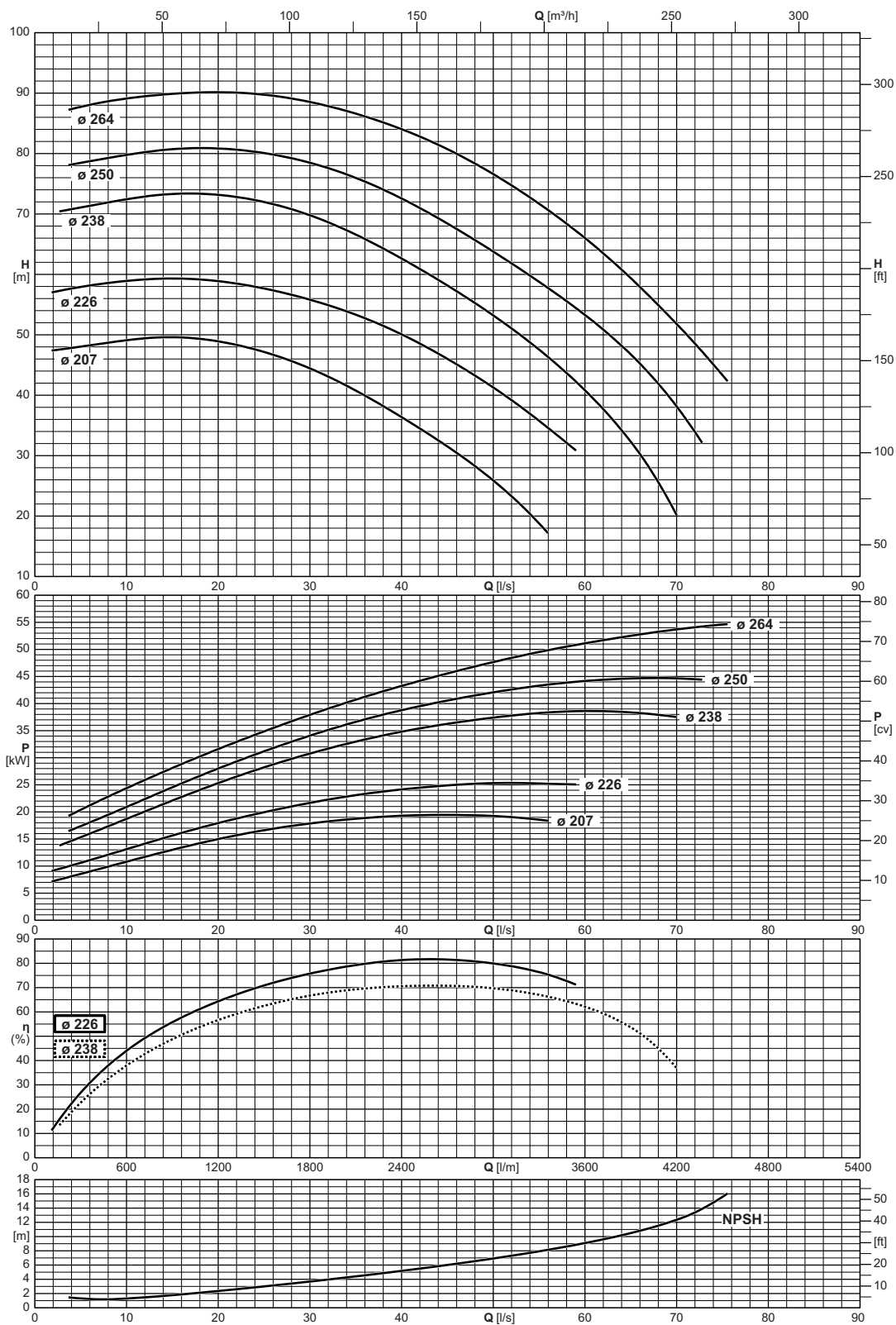

Type Type Tipo	Inlet maximum pressure Pression maximale en aspiration Pressione massima in aspirazione
NC80-250EC	[bar] 16

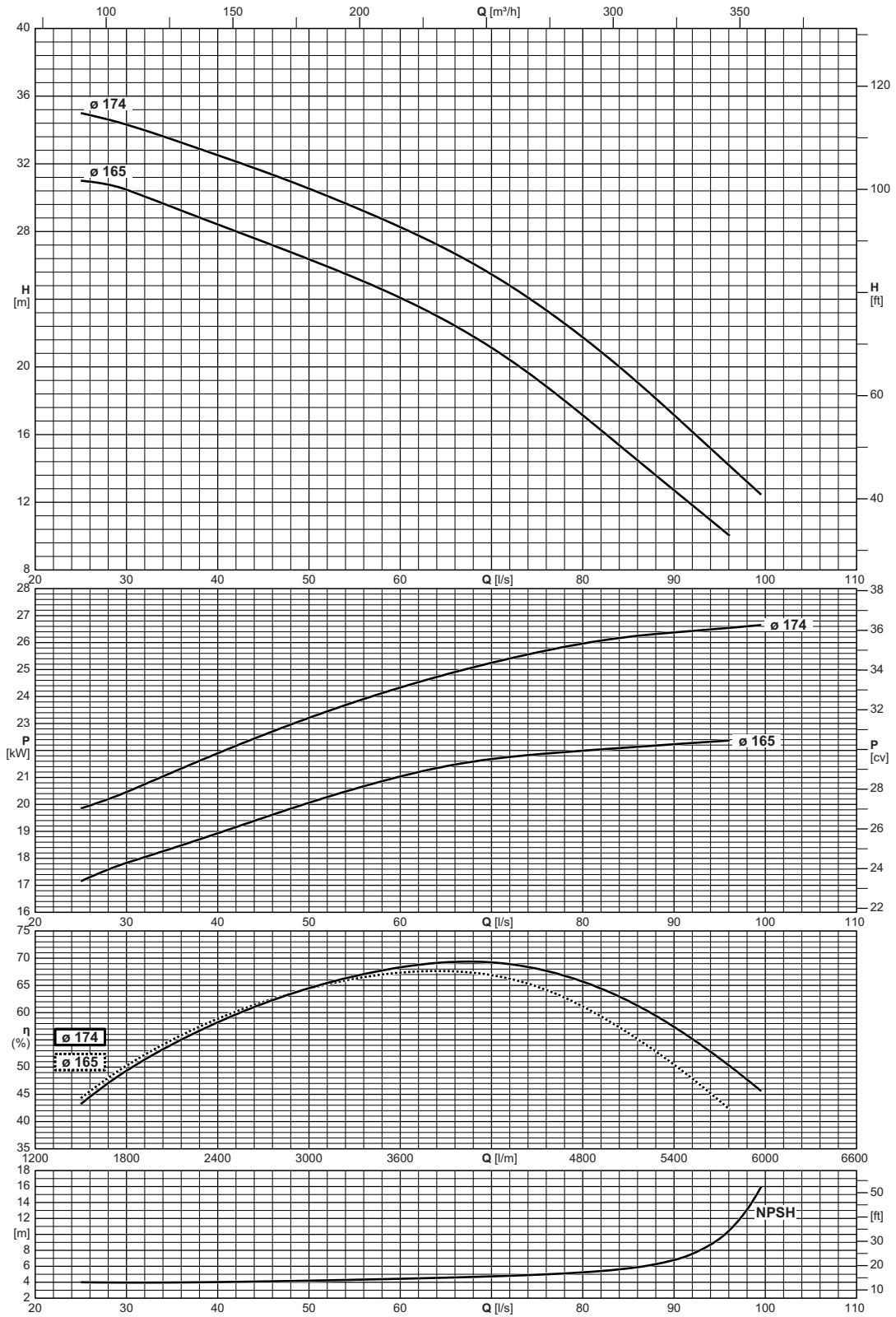

Type Type Tipo	Inlet maximum pressure Pression maximale en aspiration Pressione massima in aspirazione
NC100-160EK	[bar] 5

NC 100-200EC

2900 n [min⁻¹]



Operating data
Caracteristiques de fonctionnement
Caratteristiche di funzionamento

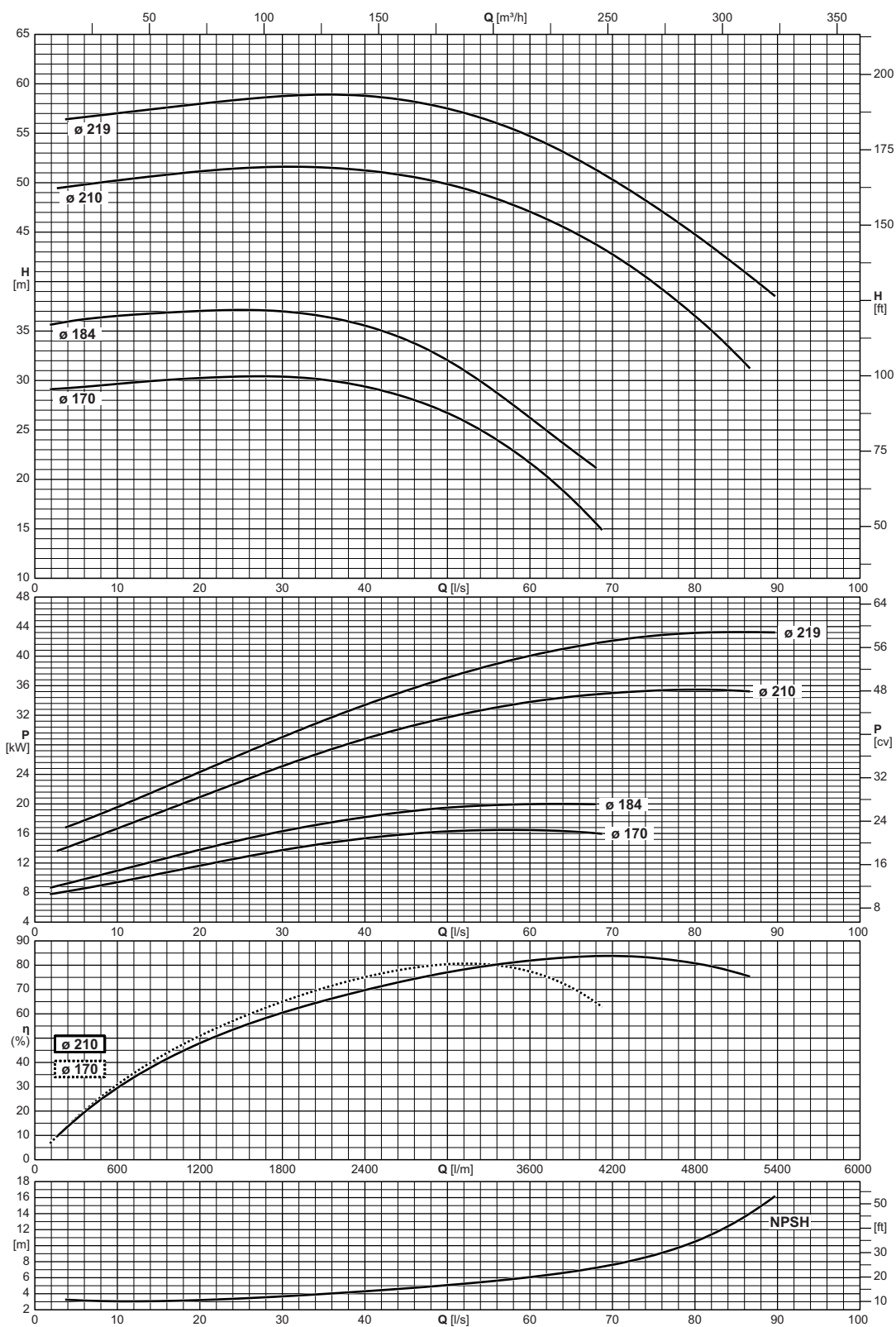

Type Type Tipo	Inlet maximum pressure Pression maximale en aspiration Pressione massima in aspirazione
NC100-200EC	[bar] 16

Operating data
 Caracteristiques de fonctionnement
 Caratteristiche di funzionamento

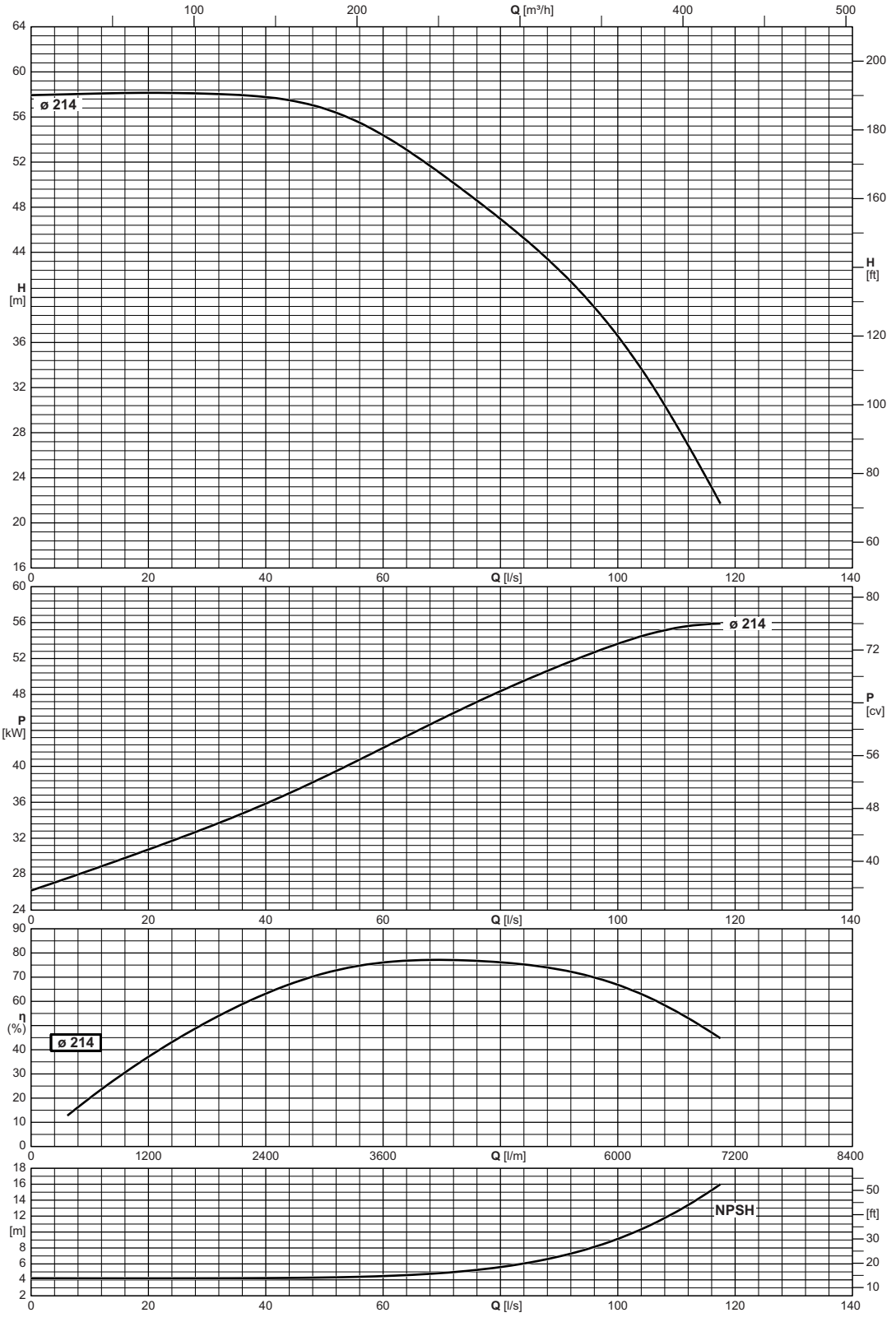

Type Type Tipo	Inlet maximum pressure Pression maximale en aspiration Pressione massima in aspirazione
	[bar]
NC100-200EK	3

NC 100-250EC

2900 n [min⁻¹]



Operating data
Caracteristiques de fonctionnement
Caratteristiche di funzionamento

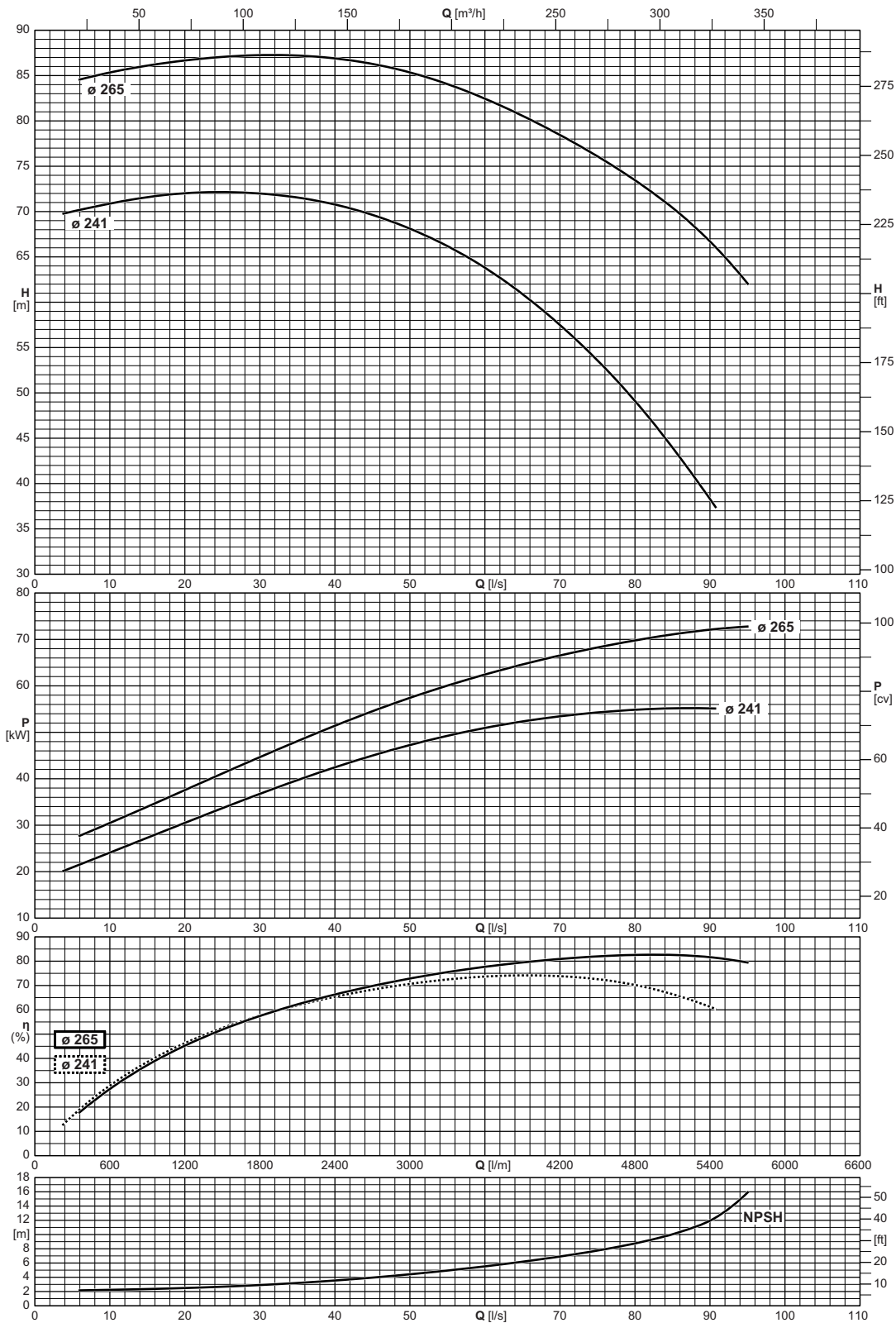

Type Type Tipo	Inlet maximum pressure Pression maximale en aspiration Pressione massima in aspirazione
NC100-250EC	[bar] 16

Operating data
 Caracteristiques de fonctionnement
 Caratteristiche di funzionamento

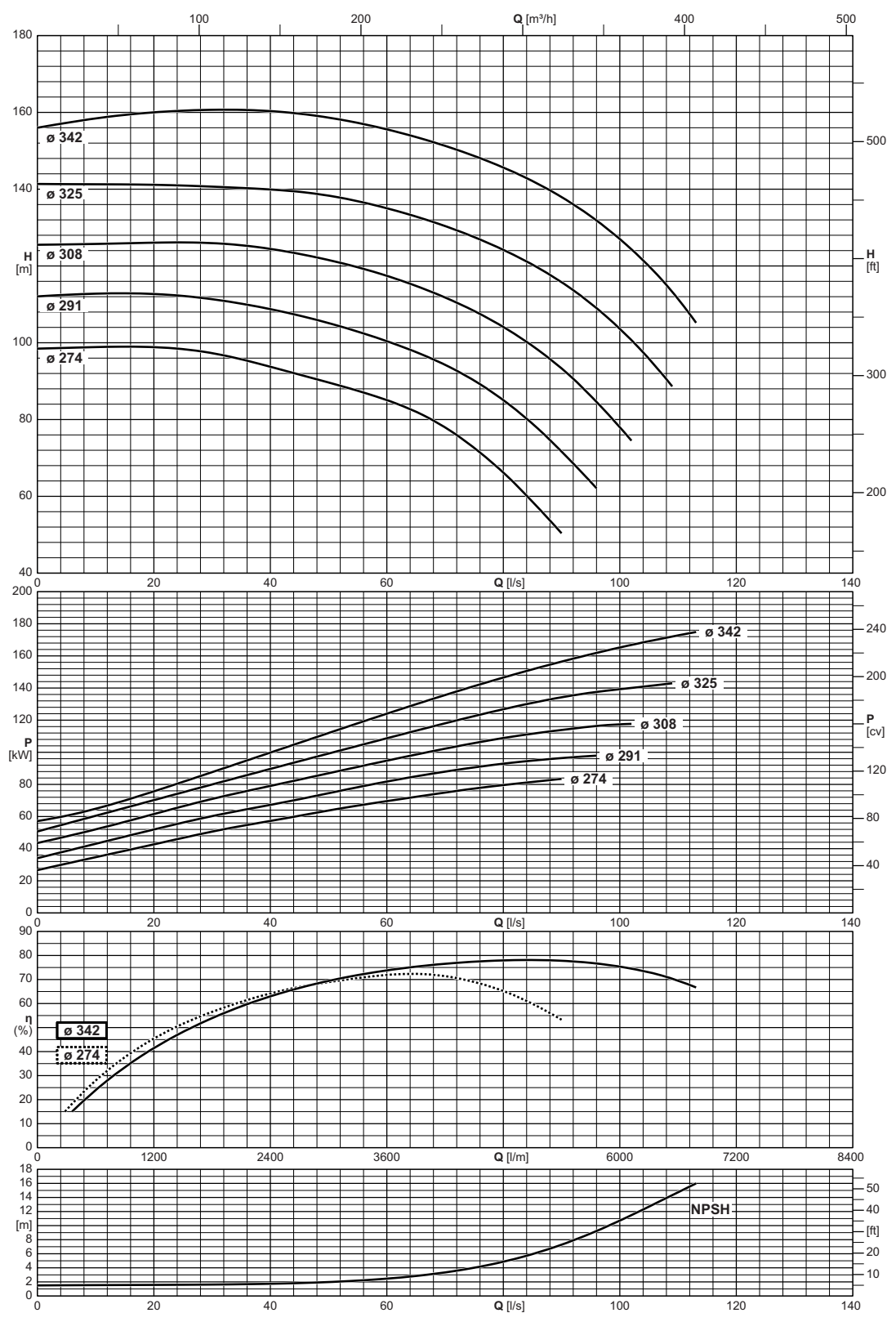

Type Type Tipo	Inlet maximum pressure Pression maximale en aspiration Pressione massima in aspirazione
	[bar]
NC100-315EK	-

NC 125-250EK

2900 n [min⁻¹]



Operating data
Caracteristiques de fonctionnement
Caratteristiche di funzionamento

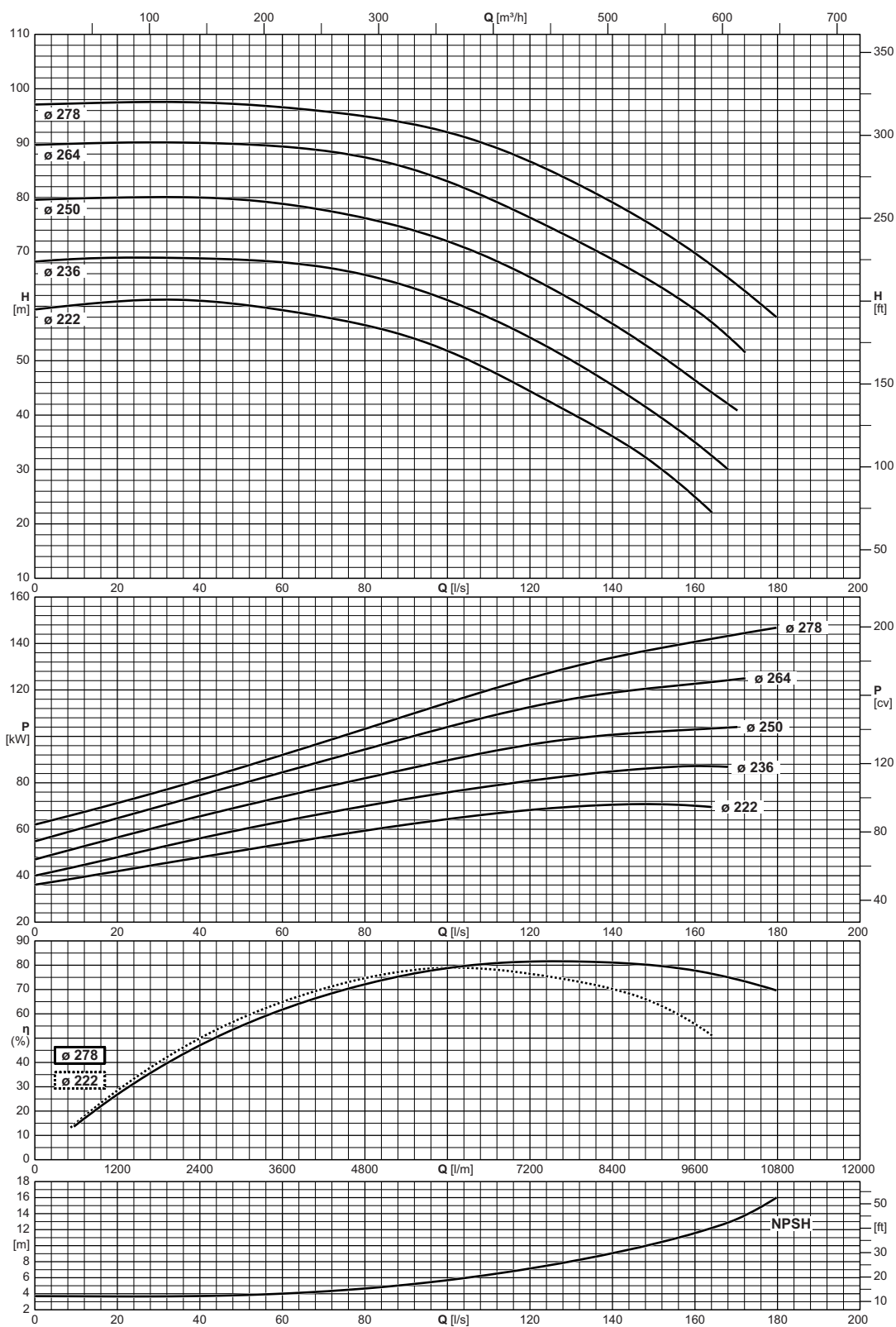

Type Type Tipo	Inlet maximum pressure Pression maximale en aspiration Pressione massima in aspirazione
NC125-250EK	[bar] 5

Operating data
 Caracteristiques de fonctionnement
 Caratteristiche di funzionamento

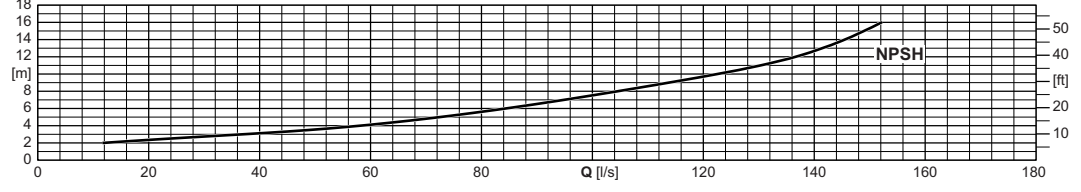
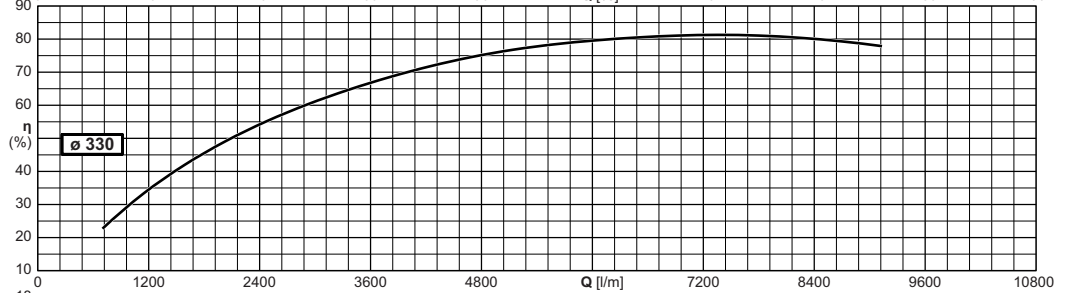
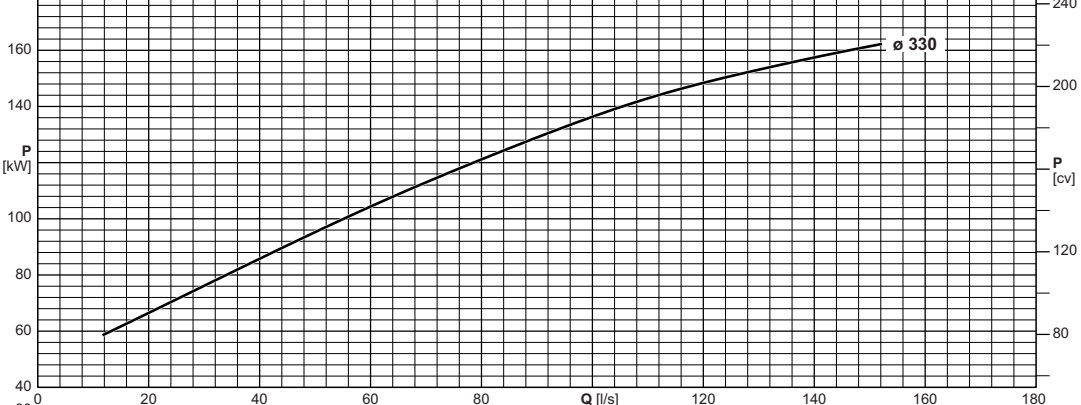
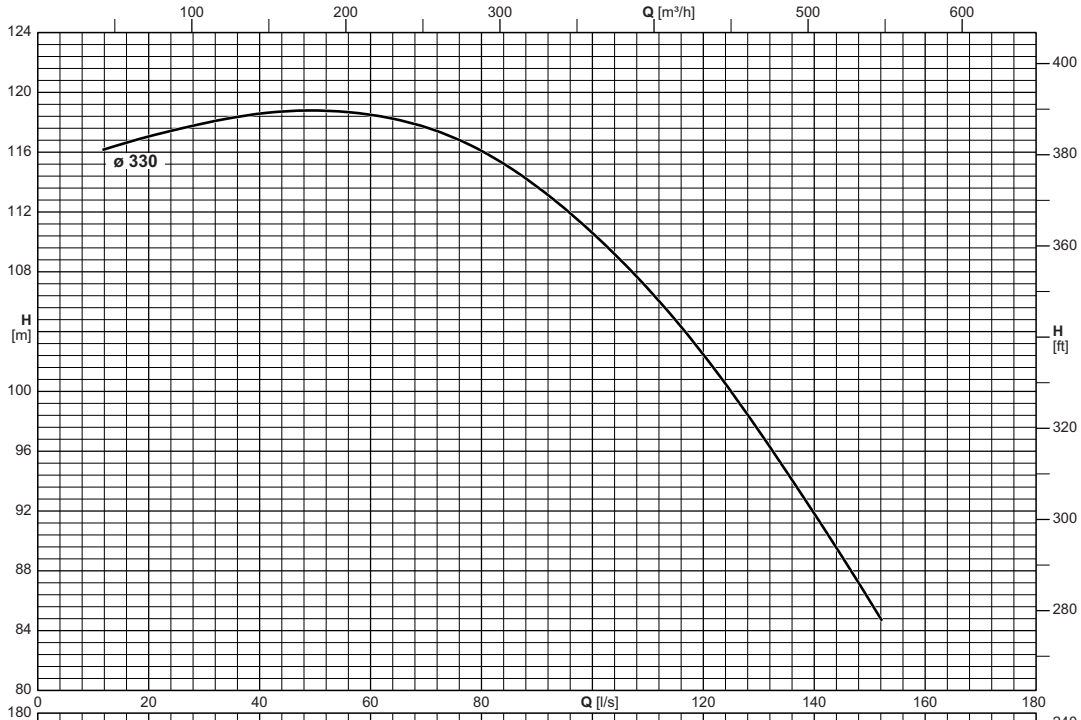

Type Type Tipo	Inlet maximum pressure Pression maximale en aspiration Pressione massima in aspirazione
	[bar]
NC125-315EC	16

NC 125-400EC

2100 n [min⁻¹]



Operating data
Caracteristiques de fonctionnement
Caratteristiche di funzionamento

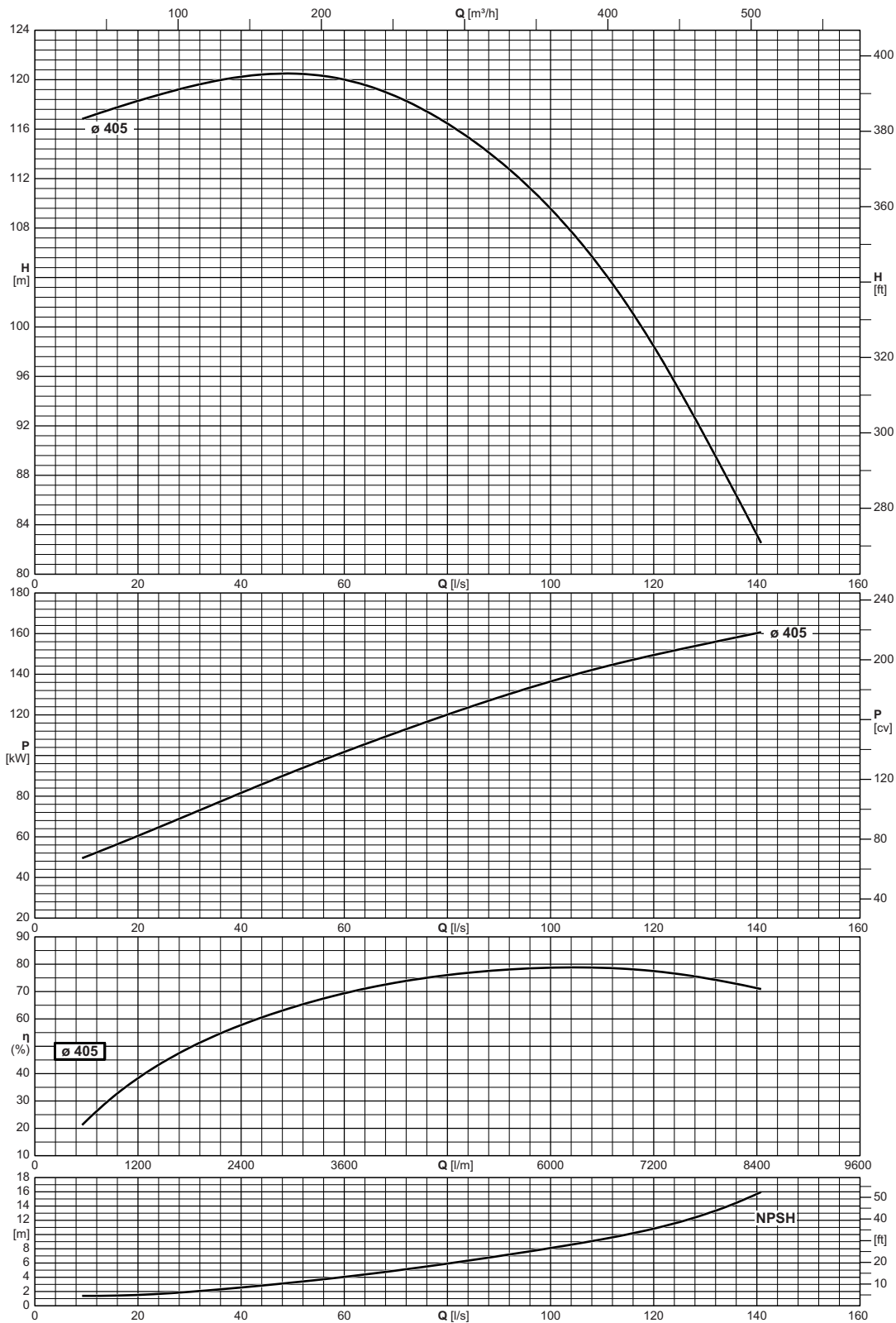

Type Type Tipo	Inlet maximum pressure Pression maximale en aspiration Pressione massima in aspirazione
NC125-400EC	[bar] 16

Operating data
 Caracteristiques de fonctionnement
 Caratteristiche di funzionamento

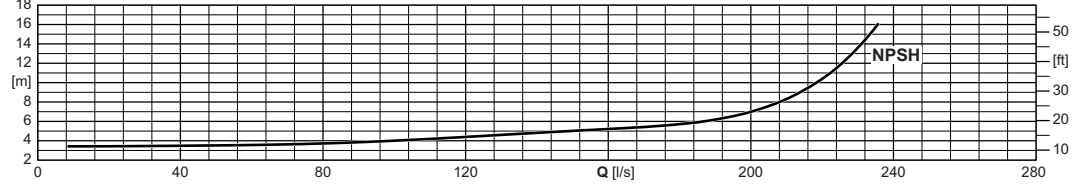
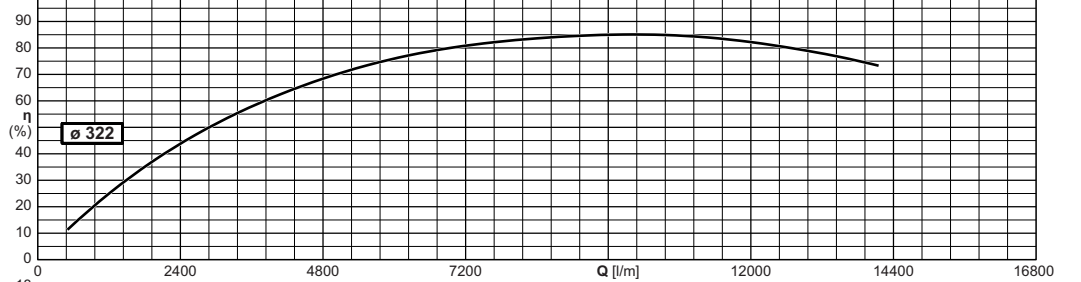
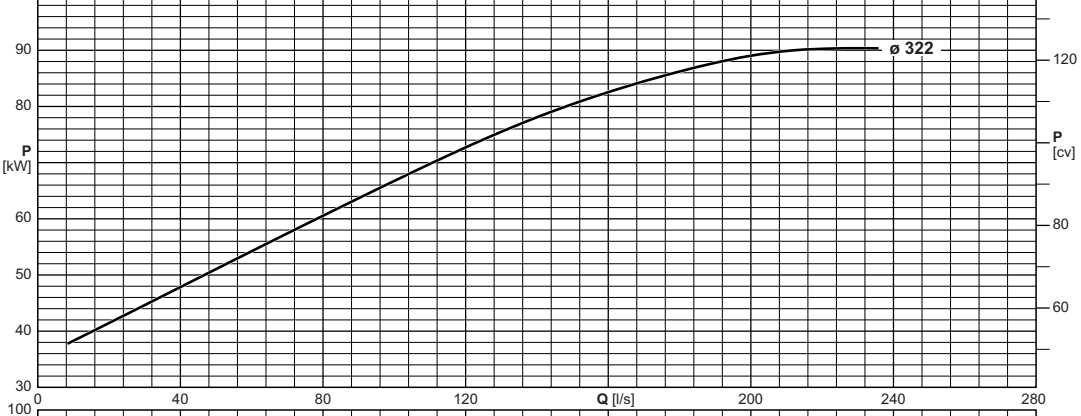
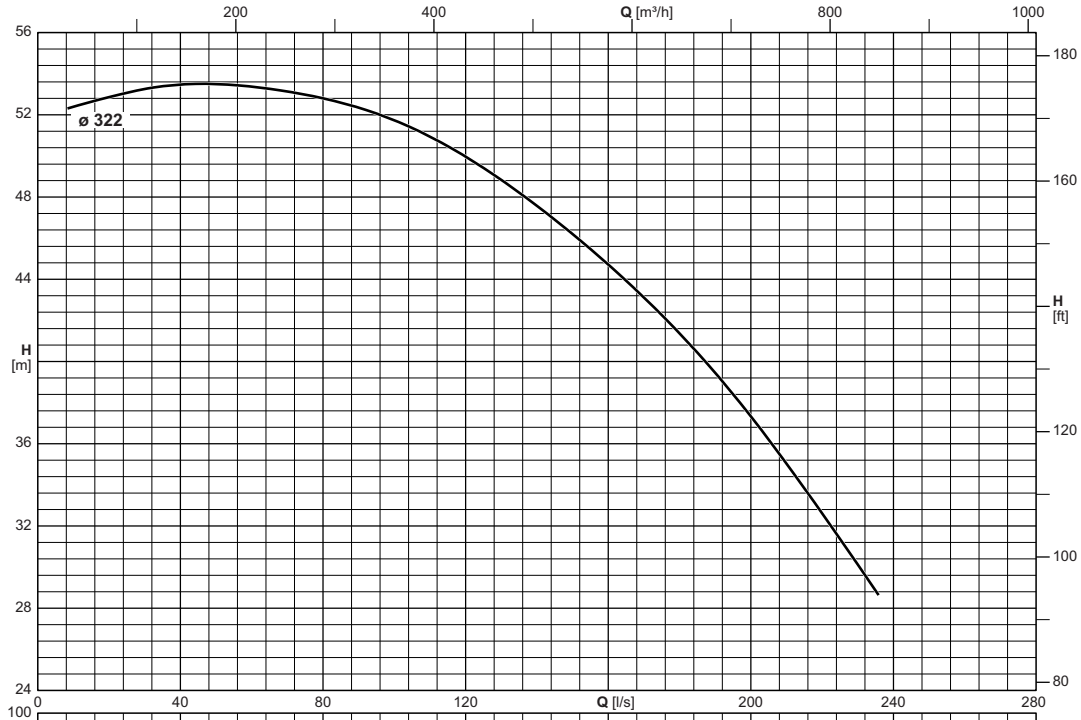

Type Type Tipo	Inlet maximum pressure Pression maximale en aspiration Pressione massima in aspirazione
NC150-315EC	[bar] 16

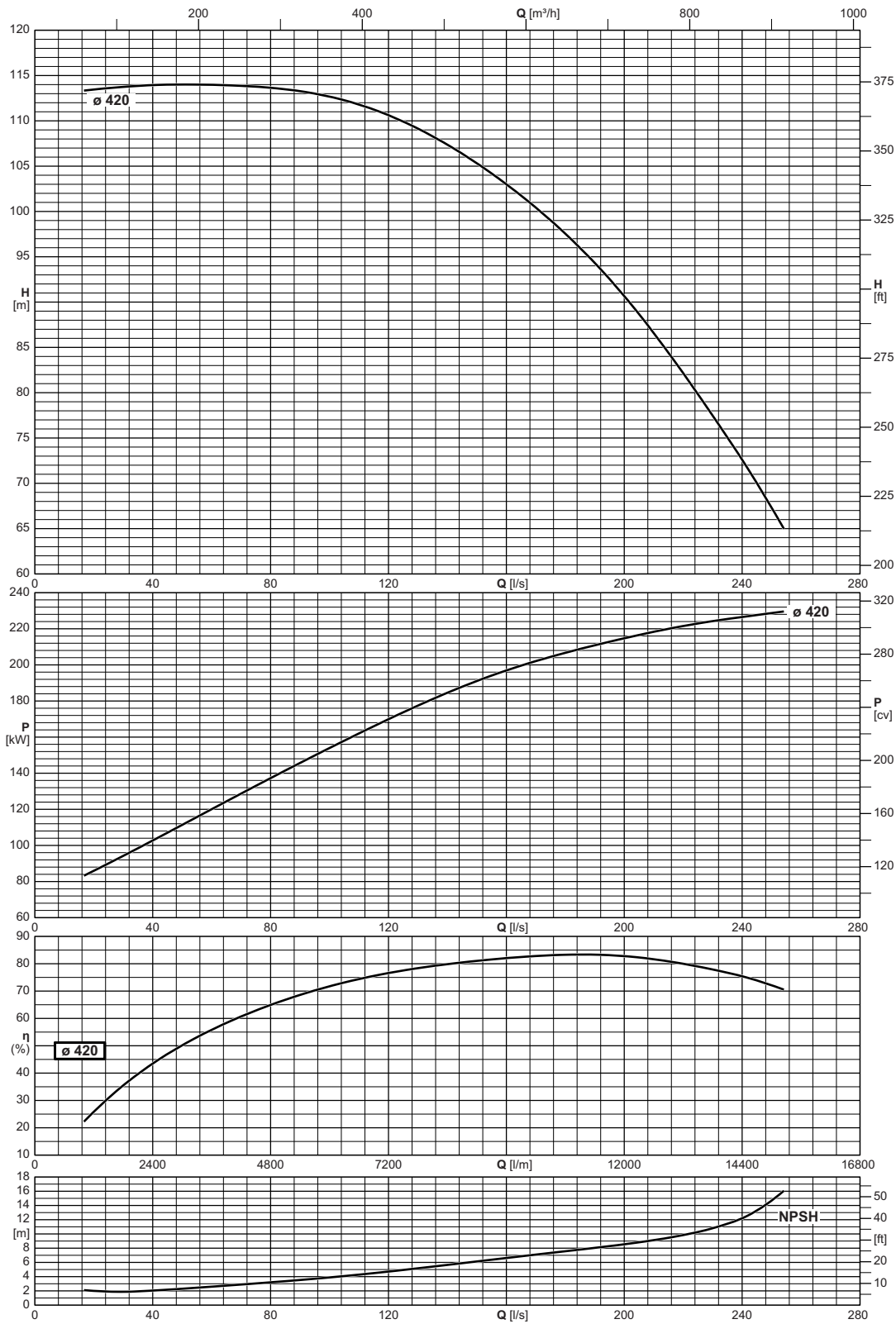

Type Type Tipo	Inlet maximum pressure Pression maximale en aspiration Pressione massima in aspirazione
NC150-400EC	[bar] 10

Overall dimensions and weights
 Dimensions d'encombrement et poids
 Dimensioni di ingombro e pesi

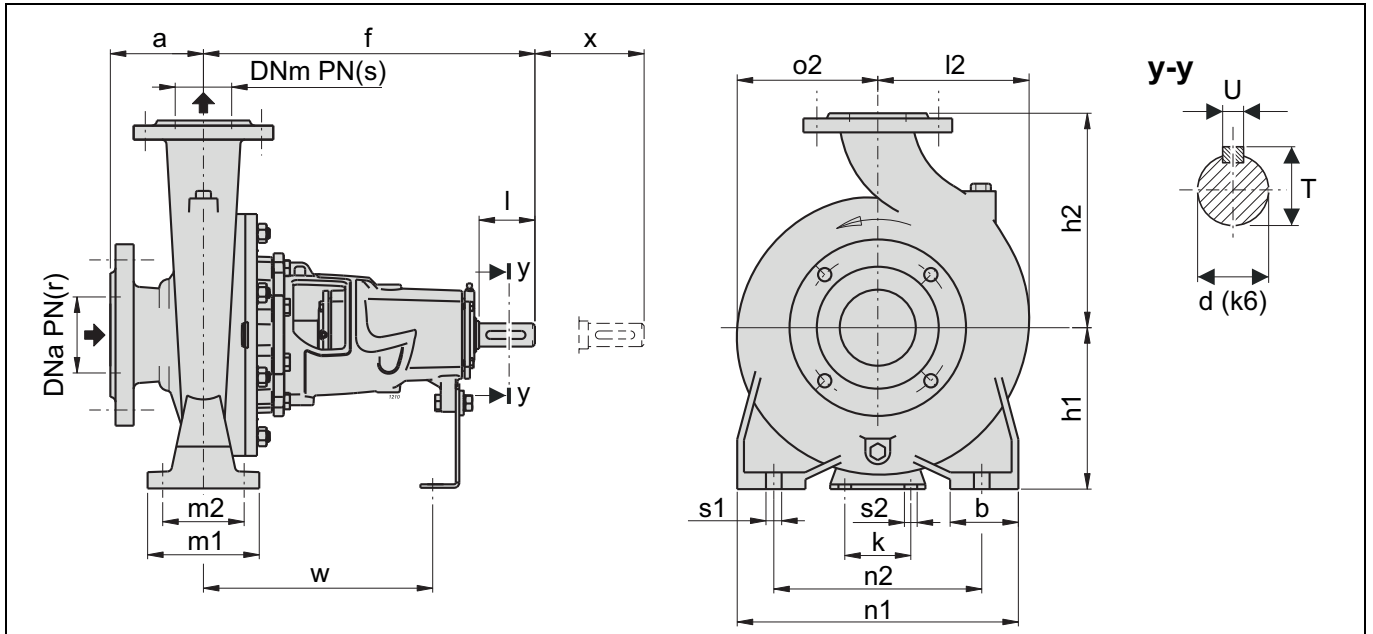

Type Type Tipo	Weight Poids Peso [kg]	Dimensions pump Dimensions pompe Dimensioni pompa																Duck foot pedestal dimensions Dimensions pieds de soutien Dimensioni piedi di appoggio										Shaft projection Saillie d'arbre Sporgenza d'albero				
		DNa	DNm	r	s	a	f	h1	h2	l2	o2	b	m1	m2	n1	n2	k	w	s1	s2	d	l	T	U	x							
		[mm]																														
NC32-200EC/204-2900	40	50	32	10-16	10-16	80	360	160	180	140	140	50	100	70	240	190	110	260	ø 14	ø 14	24	50	27	8	100							
NC40-250EC/215-2900	54	65	40	10-16	10-16	100	360	180	225	175	175	65	125	95	320	250	110	260	ø 14	ø 14	24	50	27	8	100							
NC40-250EC/227-2900	55	65	40	10-16	10-16	100	360	180	225	175	175	65	125	95	320	250	110	260	ø 14	ø 14	24	50	27	8	100							
NC40-250EC/251-2900	55	65	40	10-16	10-16	100	360	180	225	175	175	65	125	95	320	250	110	260	ø 14	ø 14	24	50	27	8	100							
NC50-160EC/174-2900	34	65	50	10-16	10-16	100	360	160	180	141	127	50	100	70	265	212	110	260	ø 14	ø 14	24	50	27	8	100							
NC50-200EC/194-2900	-	65	50	10-16	10-16	100	360	160	200	153	140	50	100	70	265	212	110	260	ø 14	ø 14	24	50	27	8	100							
NC50-200EC/206-2900	-	65	50	10-16	10-16	100	360	160	200	153	140	50	100	70	265	212	110	260	ø 14	ø 14	24	50	27	8	100							
NC50-200EC/216-2900	-	65	50	10-16	10-16	100	360	160	200	153	140	50	100	70	265	212	110	260	ø 14	ø 14	24	50	27	8	100							
NC50-250EC/218-2900	-	65	50	16	16	100	360	180	225	175	175	65	125	95	320	250	110	260	ø 14	ø 14	24	50	27	8	100							
NC50-250EC/242-2900	-	65	50	16	16	100	360	180	225	175	175	65	125	95	320	250	110	260	ø 14	ø 14	24	50	27	8	100							
NC50-250EC/256-2900	-	65	50	16	16	100	360	180	225	175	175	65	125	95	320	250	110	260	ø 14	ø 14	24	50	27	8	100							
NC65-160EC/160-2900	40	80	65	10-16	10-16	100	360	160	200	172	150	65	125	95	280	212	110	260	ø 14	ø 14	24	50	27	8	100							
NC65-160EC/175-2900	40	80	65	10-16	10-16	100	360	160	200	172	150	65	125	95	280	212	110	260	ø 14	ø 14	24	50	27	8	100							
NC65-200EC/188-2900	-	80	65	10-16	10-16	100	360	180	225	175	155	65	125	95	320	250	110	260	ø 14	ø 14	24	50	27	8	140							
NC65-200EC/202-2900	-	80	65	10-16	10-16	100	360	180	225	175	155	65	125	95	320	250	110	260	ø 14	ø 14	24	50	27	8	140							
NC65-200EC/215-2900	-	80	65	10-16	10-16	100	360	180	225	175	155	65	125	95	320	250	110	260	ø 14	ø 14	24	50	27	8	140							
NC65-250EC/212-2900	87	80	65	10-16	10-16	100	470	200	250	190	175	80	160	120	360	280	110	340	ø 18	ø 14	32	80	35	10	140							
NC65-250EC/232-2900	88	80	65	10-16	10-16	100	470	200	250	190	175	80	160	120	360	280	110	340	ø 18	ø 14	32	80	35	10	140							
NC65-250EC/249-2900	89	80	65	10-16	10-16	100	470	200	250	190	175	80	160	120	360	280	110	340	ø 18	ø 14	32	80	35	10	140							
NC80-250EC/207-2900	91	100	80	10-16	10-16	125	470	200	280	210	191	80	160	120	400	315	110	340	ø 18	ø 14	32	80	35	10	140							
NC80-250EC/226-2900	91	100	80	10-16	10-16	125	470	200	280	210	191	80	160	120	400	315	110	340	ø 18	ø 14	32	80	35	10	140							
NC80-250EC/238-2900	92	100	80	10-16	10-16	125	470	200	280	210	191	80	160	120	400	315	110	340	ø 18	ø 14	32	80	35	10	140							
NC80-250EC/250-2900	93	100	80	10-16	10-16	125	470	200	280	210	191	80	160	120	400	315	110	340	ø 18	ø 14	32	80	35	10	140							
NC80-250EC/264-2900	92	100	80	10-16	10-16	125	470	200	280	210	191	80	160	120	400	315	110	340	ø 18	ø 14	32	80	35	10	140							
NC100-200EC/170-2900	82	125	100	10-16	10-16	125	470	200	280	212	180	80	160	120	360	280	110	340	ø 18	ø 14	32	80	35	10	140							
NC100-200EC/184-2900	83	125	100	10-16	10-16	125	470	200	280	212	180	80	160	120	360	280	110	340	ø 18	ø 14	32	80	35	10	140							
NC100-200EC/210-2900	83	125	100	10-16	10-16	125	470	200	280	212	180	80	160	120	360	280	110	340	ø 18	ø 14	32	80	35	10	140							
NC100-200EC/219-2900	84	125	100	10-16	10-16	125	470	200	280	212	180	80	160	120	360	280	110	340	ø 18	ø 14	32	80	35	10	140							
NC100-250EC/241-2900	100	125	100	10-16	10-16	140	470	225	280	233	205	80	160	120	400	315	110	340	ø 18	ø 14	32	80	35	10	140							
NC100-250EC/265-2900	104	125	100	10-16	10-16	140	470	225	280	233	205	80	160	120	400	315	110	340	ø 18	ø 14	32	80	35	10	140							
NC125-315EC/330-2640	189	150	125	10-16	10-16	140	530	280	355	278	247	100	200	150	500	400	110	370	ø 22	ø 14	42	110	45	12	140							
NC125-400EC/405-2100	221	150	125	10-16	10-16	140	530	315	400	305	280	100	200	150	500	400	110	370	ø 22	ø 14	42	110	45	12	140							
NC150-315EC/322-1480	198	200	150	10	10-16	160	530	280	400	298	260	100	200	150	550	450	110	370	ø 22	ø 14	42	110	45	12	140							
NC150-400EC/420-2045	250	200	150	10	10-16	160	530	315	450	328	295	100	200	150	550	450	110	370	ø 22	ø 14	42	110	45	12	140							

Overall dimensions and weights
 Dimensions d'encombrement et poids
 Dimensioni di ingombro e pesi

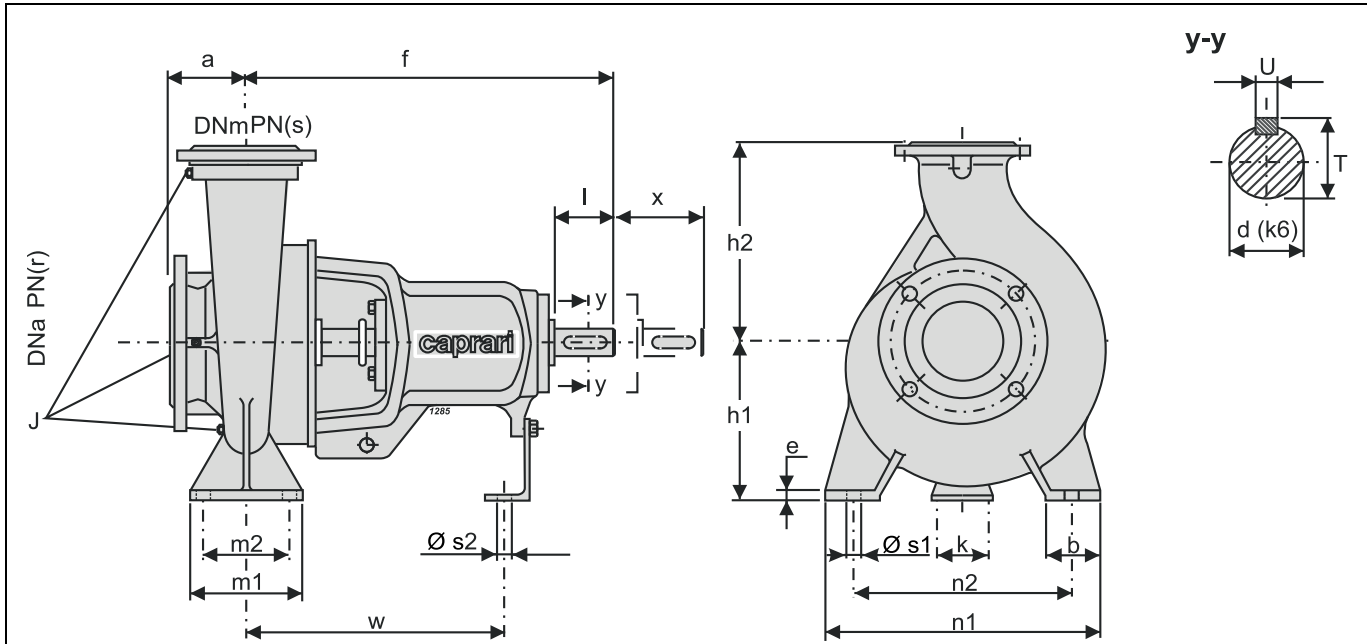

Type Type Tipo	Weight Poids Peso [kg]	Dimensions pump Dimensions pompe Dimensioni pompa										Duck foot pedestal dimensions Dimensiones pieds de soutien Dimensioni piedi di appoggio										Shaft projection Saillie d'arbre Sporgenza d'albero				
		DNa	DNm	J	r	s	a	f	h1	h2	b	k	e	m1	m2	n1	n2	w	s1	s2	d	l	T	U	x	
		[mm]																								
NC32-250EK/225-2900	60	50	32	G1/4,G3/8x2,G1/4	16	16	100	360	180	225	65	110	14	125	95	320	250	260	Ø 14	Ø 14	24	50	27	8	100	
NC32-250EK/235-2900	60	50	32	G1/4,G3/8x2,G1/4	16	16	100	360	180	225	65	110	14	125	95	320	250	260	Ø 14	Ø 14	24	50	27	8	100	
NC32-250EK/245-2900	60	50	32	G1/4,G3/8x2,G1/4	16	16	100	360	180	225	65	110	14	125	95	320	250	260	Ø 14	Ø 14	24	50	27	8	100	
NC32-250EK/255-2900	60	50	32	G1/4,G3/8x2,G1/4	16	16	100	360	180	225	65	110	14	125	95	320	250	260	Ø 14	Ø 14	24	50	27	8	100	
NC32-250EK/264-2900	60	50	32	G1/4,G3/8x2,G1/4	16	16	100	360	180	225	65	110	14	125	95	320	250	260	Ø 14	Ø 14	24	50	27	8	100	
NC40-200EK/175-2900	45	65	40	G1/4,G3/8x2,G1/4	16	16	100	360	160	180	50	110	14	100	70	265	212	260	Ø 14	Ø 14	24	50	27	8	100	
NC40-200EK/185-2900	45	65	40	G1/4,G3/8x2,G1/4	16	16	100	360	160	180	50	110	14	100	70	265	212	260	Ø 14	Ø 14	24	50	27	8	100	
NC40-200EK/195-2900	45	65	40	G1/4,G3/8x2,G1/4	16	16	100	360	160	180	50	110	14	100	70	265	212	260	Ø 14	Ø 14	24	50	27	8	100	
NC40-200EK/205-2900	45	65	40	G1/4,G3/8x2,G1/4	16	16	100	360	160	180	50	110	14	100	70	265	212	260	Ø 14	Ø 14	24	50	27	8	100	
NC40-200EK/214-2900	45	65	40	G1/4,G3/8x2,G1/4	16	16	100	360	160	180	50	110	14	100	70	265	212	260	Ø 14	Ø 14	24	50	27	8	100	
NC40-250EK/225-2900	61	65	40	G1/4,G3/8x2,G1/4	16	16	100	360	180	225	65	110	14	125	95	320	250	260	Ø 14	Ø 14	24	50	27	8	100	
NC40-250EK/235-2900	61	65	40	G1/4,G3/8x2,G1/4	16	16	100	360	180	225	65	110	14	125	95	320	250	260	Ø 14	Ø 14	24	50	27	8	100	
NC40-250EK/245-2900	61	65	40	G1/4,G3/8x2,G1/4	16	16	100	360	180	225	65	110	14	125	95	320	250	260	Ø 14	Ø 14	24	50	27	8	100	
NC40-250EK/255-2900	61	65	40	G1/4,G3/8x2,G1/4	16	16	100	360	180	225	65	110	14	125	95	320	250	260	Ø 14	Ø 14	24	50	27	8	100	
NC40-250EK/264-2900	61	65	40	G1/4,G3/8x2,G1/4	16	16	100	360	180	225	65	110	14	125	95	320	250	260	Ø 14	Ø 14	24	50	27	8	100	
NC50-125EK/120-2900	34	65	50	G1/4x2,G3/8,G1/4	16	16	100	360	132	160	50	100	14	100	70	240	190	260	Ø 14	Ø 14	24	50	27	8	100	
NC50-125EK/130-2900	34	65	50	G1/4x2,G3/8,G1/4	16	16	100	360	132	160	50	100	14	100	70	240	190	260	Ø 14	Ø 14	24	50	27	8	100	
NC50-125EK/139-2900	34	65	50	G1/4x2,G3/8,G1/4	16	16	100	360	132	160	50	100	14	100	70	240	190	260	Ø 14	Ø 14	24	50	27	8	100	
NC50-160EK/135-2900	38	65	50	G1/4,G3/8x2,G1/4	16	16	100	360	160	180	50	110	14	100	70	265	212	260	Ø 14	Ø 14	24	50	27	8	100	
NC50-160EK/145-2900	38	65	50	G1/4,G3/8x2,G1/4	16	16	100	360	160	180	50	110	14	100	70	265	212	260	Ø 14	Ø 14	24	50	27	8	100	
NC50-160EK/155-2900	38	65	50	G1/4,G3/8x2,G1/4	16	16	100	360	160	180	50	110	14	100	70	265	212	260	Ø 14	Ø 14	24	50	27	8	100	
NC50-160EK/165-2900	38	65	50	G1/4,G3/8x2,G1/4	16	16	100	360	160	180	50	110	14	100	70	265	212	260	Ø 14	Ø 14	24	50	27	8	100	
NC50-160EK/174-2900	38	65	50	G1/4,G3/8x2,G1/4	16	16	100	360	160	180	50	110	14	100	70	265	212	260	Ø 14	Ø 14	24	50	27	8	100	
NC50-315EK/274-2900	87	80	50	G1/4x3	16	25	125	500	225	280	65	110	18	125	95	345	280	370	Ø 14	Ø 14	32	80	35	10	100	
NC50-315EK/291-2900	87	80	50	G1/4x3	16	25	125	500	225	280	65	110	18	125	95	345	280	370	Ø 14	Ø 14	32	80	35	10	100	
NC50-315EK/308-2900	87	80	50	G1/4x3	16	25	125	500	225	280	65	110	18	125	95	345	280	370	Ø 14	Ø 14	32	80	35	10	100	
NC50-315EK/325-2900	87	80	50	G1/4x3	16	25	125	500	225	280	65	110	18	125	95	345	280	370	Ø 14	Ø 14	32	80	35	10	100	
NC50-315EK/342-2900	87	80	50	G1/4x3	16	25	125	500	225	280	65	110	18	125	95	345	280	370	Ø 14	Ø 14	32	80	35	10	100	
NC65-125EK/120-2900	39	80	65	G1/4x2,G3/8,G1/4	16	16	100	360	160	180	65	110	14	125	95	280	212	260	Ø 14	Ø 14	24	50	27	8	100	
NC65-125EK/130-2900	39	80	65	G1/4x2,G3/8,G1/4	16	16	100	360	160	180	65	110	14	125	95	280	212	260	Ø 14	Ø 14	24	50	27	8	100	
NC65-125EK/139-2900	39	80	65	G1/4x2,G3/8,G1/4	16	16	100	360	160	180	65	110	14	125	95	280	212	260	Ø 14	Ø 14	24	50	27	8	100	
NC65-160EK/145-2900	43	80	65	G1/4,G3/8x2,G1/4	16	16	100	360	160	200	65	110	14	125	95	280	212	260	Ø 14	Ø 14	24	50	27	8	100	
NC65-160EK/155-2900	43	80	65	G1/4,G3/8x2,G1/4	16	16	100	360	160	200	65	110	14	125	95	280	212	260	Ø 14	Ø 14	24	50	27	8	100	
NC65-160EK/165-2900	43	80	65	G1/4,G3/8x2,G1/4	16	16	100	360	160	200	65	110	14	125	95	280	212	260	Ø 14	Ø 14	24	50	27	8	100	
NC65-160EK/174-2900	43	80	65	G1/4,G3/8x2,G1/4	16	16	100	360	160	200	65	110	14	125	95	280	212	260	Ø 14	Ø 14	24	50	27	8	100	
NC65-200EK/175-2900	52	80	65	G1/4,G3/8x2,G1/4	16	16	100	360	180	225	65	110	14	125	95	320	250	260	Ø 14	Ø 14	24	50	27	8	100	
NC65-200EK/185-2900	52	80	65	G1/4,G3/8x2,G1/4	16	16	100	360	180	225	65	110	14	125	95	320	250	260	Ø 14	Ø 14	24	50	27	8	100	
NC65-200EK/195-2900	52	80	65	G1/4,G3/8x2,G1/4	16	16	100	360	180	225	65	110	14	125	95	320	250	260	Ø 14	Ø 14	24	50	27	8	100	
NC65-200EK/205-2900	52	80	65	G1/4,G3/8x2,G1/4	16	16	100	360	180	225	65	110	14	125	95	320	250	260	Ø 14	Ø 14	24	50	27	8	100	
NC65-200EK/214-2900	52	80	65	G1/4,G3/8x2,G1/4	16	16	100	360	180	225	65	110	14	125	95	320	250	260	Ø 14	Ø 14	24	50	27	8	100	
NC65-250EK/225-2900	81	80	65	G1/4,G3/8x2,G1/4	16	16	100	470	200	250	80	110	16	160	120	360	280	340	Ø 18	Ø 14	32	80	35	10	100	
NC65-250EK/235-2900	81	80	65	G1/4,G3/8x2,G1/4	16	16	100	470	200	250	80	110	16	160	120	360	280	340	Ø 18	Ø 14	32	80	35	10	100	
NC65-250EK/245-2900	81	80	65	G1/4,G3/8x2,G1/4	16	16	100	470	200	250	80	110	16	160	120	360	280	340	Ø 18	Ø 14	32	80	35	10	100	

Overall dimensions and weights
 Dimensions d'encombrement et poids
 Dimensioni di ingombro e pesi

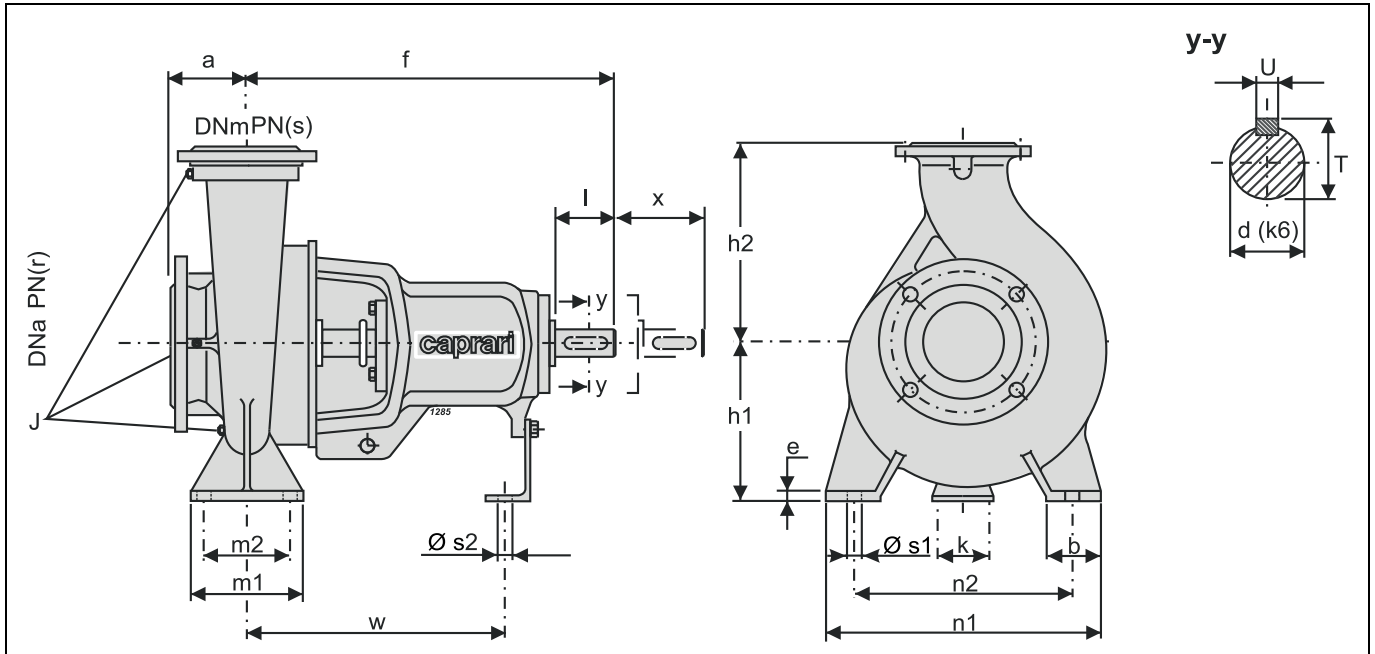

Type Type Tipo	Weight Poids Peso [kg]	Dimensions pump Dimensions pompe Dimensioni pompa																Duck foot pedestal dimensions Dimensions pieds de soutien Dimensioni piedi di appoggio										Shaft projection Saillie d'arbre Sporgenza d'albero				
		DNa	DNm	J	r	s	a	f	h1	h2	b	k	e	m1	m2	n1	n2	w	s1	s2	d	l	T	U	x							
		[mm]																														
NC65-250EK/255-2900	81	80	65	G1/4,G3/8x2,G1/4	16	16	100	470	200	250	80	110	16	160	120	360	280	340	ø 18	ø 14	32	80	35	10	100							
NC65-250EK/264-2900	81	80	65	G1/4,G3/8x2,G1/4	16	16	100	470	200	250	80	110	16	160	120	360	280	340	ø 18	ø 14	32	80	35	10	100							
NC80-200EK/175-2900	75	100	80	G1/4,G3/8x2,G1/4	16	16	125	470	180	250	65	110	14	125	95	345	280	340	ø 14	ø 14	32	80	35	10	100							
NC80-200EK/185-2900	75	100	80	G1/4,G3/8x2,G1/4	16	16	125	470	180	250	65	110	14	125	95	345	280	340	ø 14	ø 14	32	80	35	10	100							
NC80-200EK/195-2900	75	100	80	G1/4,G3/8x2,G1/4	16	16	125	470	180	250	65	110	14	125	95	345	280	340	ø 14	ø 14	32	80	35	10	100							
NC80-200EK/205-2900	75	100	80	G1/4,G3/8x2,G1/4	16	16	125	470	180	250	65	110	14	125	95	345	280	340	ø 14	ø 14	32	80	35	10	100							
NC80-200EK/214-2900	75	100	80	G1/4,G3/8x2,G1/4	16	16	125	470	180	250	65	110	14	125	95	345	280	340	ø 14	ø 14	32	80	35	10	100							
NC100-160EK/165-2900	72	125	100	G3/8x3, G1/4	16	16	125	470	200	250	80	110	16	160	120	360	280	340	ø 18	ø 14	32	80	35	10	140							
NC100-160EK/174-2900	72	125	100	G3/8x3, G1/4	16	16	125	470	200	250	80	110	16	160	120	360	280	340	ø 18	ø 14	32	80	35	10	140							
NC100-200EK/214-2900	86	125	100	G3/8x3,G1/4	16	16	125	470	200	280	80	110	16	160	120	360	280	340	ø 18	ø 14	32	80	35	10	140							
NC100-315EK/274-2900	135	125	100	G1/4x3	16	16	140	530	250	315	80	110	19	160	120	400	315	370	ø 18	ø 14	42	110	45	12	140							
NC100-315EK/291-2900	135	125	100	G1/4x3	16	16	140	530	250	315	80	110	19	160	120	400	315	370	ø 18	ø 14	42	110	45	12	140							
NC100-315EK/308-2900	135	125	100	G1/4x3	16	16	140	530	250	315	80	110	19	160	120	400	315	370	ø 18	ø 14	42	110	45	12	140							
NC100-315EK/325-2900	135	125	100	G1/4x3	16	16	140	530	250	315	80	110	19	160	120	400	315	370	ø 18	ø 14	42	110	45	12	140							
NC100-315EK/342-2900	135	125	100	G1/4x3	16	16	140	530	250	315	80	110	19	160	120	400	315	370	ø 18	ø 14	42	110	45	12	140							
NC125-250EK/222-2900	140	150	125	G1/4x3	16	16	140	530	250	355	80	110	19	160	120	400	315	370	ø 18	ø 14	42	110	45	12	140							
NC125-250EK/236-2900	140	150	125	G1/4x3	16	16	140	530	250	355	80	110	19	160	120	400	315	370	ø 18	ø 14	42	110	45	12	140							
NC125-250EK/250-2900	140	150	125	G1/4x3	16	16	140	530	250	355	80	110	19	160	120	400	315	370	ø 18	ø 14	42	110	45	12	140							
NC125-250EK/264-2900	140	150	125	G1/4x3	16	16	140	530	250	355	80	110	19	160	120	400	315	370	ø 18	ø 14	42	110	45	12	140							
NC125-250EK/278-2900	140	150	125	G1/4x3	16	16	140	530	250	355	80	110	19	160	120	400	315	370	ø 18	ø 14	42	110	45	12	140							

Flanges (UNI EN 1092-2)
 Brides (UNI EN 1092-2)
 Flange (UNI EN 1092-2)

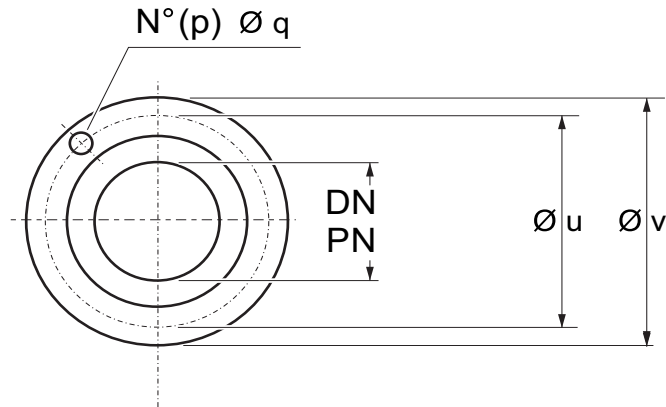

Port \varnothing \varnothing Orifice \varnothing Bocca		Holes Trous Fori		$\varnothing u$	$\varnothing v$
DN [mm]	PN [bar]	p No	q \varnothing [mm]	[mm]	
32	10/16	4	19	100	140
40	10/16	4	19	110	150
50	10/16	4	19	125	165
65	10/16	4	19	145	185
80	10/16	8	19	160	200
100	10/16	8	19	180	220
125	10/16	8	19	210	250
150	10/16	8	23	240	285
200	10	8	23	295	340
200	16	12	23	295	340
250	16	12	28	355	405

Flanges (UNI EN 1092-2)
 Brides (UNI EN 1092-2)
 Flange (UNI EN 1092-2)

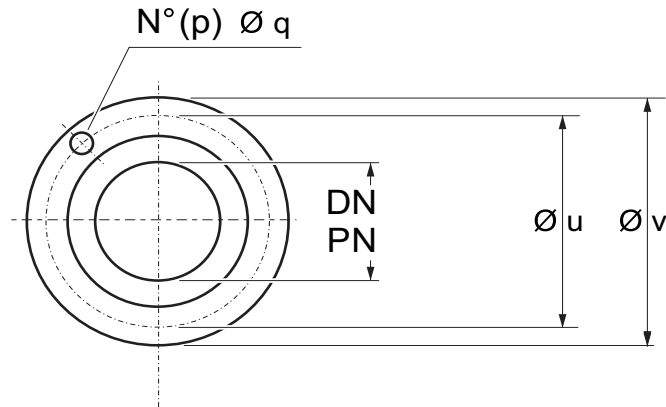

Port \varnothing \varnothing Orifice \varnothing Bocca		Holes Trous Fori		$\varnothing u$	$\varnothing v$
DN [mm]	PN [bar]	p No	q \varnothing [mm]	[mm]	
32	16	4	18	100	140
40	16	4	18	110	150
50	16	4	18	125	165
50	25	4	18	125	165
65	16	4	18	145	185
80	16	8	18	160	200
100	16	8	18	180	220
125	16	8	18	210	250
150	16	8	22	240	285
200	16	12	22	295	340
250	16	12	26	355	405
300	16	12	26	410	460

caprari

The dimensions have an indicative value. Executive drawing will be supplied on request upon order.
CAPRARI S.p.A. reserves the right to make changes to improve its products at any time and without any notice

*Les dimensions sont fournies à titre indicatif. Le plan bon pour exécution sera fourni sur demande au moment de la commande.
CAPRARI S.p.A. se réserve la faculté d'apporter des modifications visant à améliorer ses propres produits à tout moment et sans aucun préavis.*

Le dimensioni hanno valore indicativo. Il disegno esecutivo sarà fornito su richiesta in fase d'ordine.
CAPRARI S.p.A. si riserva facoltà di apportare modifiche atte a migliorare i propri prodotti in qualsiasi momento e senza preavviso alcuno.